

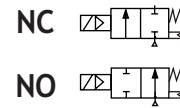

Pilot Operated
General Service Solenoid Valves
 Brass or Stainless Steel Bodies
 3/8" to 2 1/2" NPT



2/2
 SERIES
8210

Features

- Wide range of pressure ratings, sizes, and resilient materials provide long service life and low internal leakage.
- High Flow Valves for liquid, corrosive, and air/inert gas service.
- Industrial applications include:
 - Car wash
 - Laundry equipment
 - Air compressors
 - Industrial water control
 - Pumps

Construction

Valve Parts in Contact with Fluids		
Body	Brass	304 Stainless Steel
Seals and Discs	NBR or PTFE	
Disc-Holder	PA	
Core Tube	305 Stainless Steel	
Core and Plugnut	430F Stainless Steel	
Springs	302 Stainless Steel	
Shading Coil	Copper	Silver

Electrical

Standard Coil and Class of Insulation	Watt Rating and Power Consumption				Spare Coil Part Number			
	DC Watts	AC			General Purpose		Explosionproof	
		Watts	VA Holding	VA Inrush	AC	DC	AC	DC
F	-	6.1	16	40	238210	-	238214	-
F	11.6	10.1	25	70	238610	238710	238614	238714
F	16.8	16.1	35	180	272610	97617	272614	97617
F	-	17.1	40	93	238610	-	238614	-
F	-	20	43	240	99257	-	99257	-
F	-	20.1	48	240	272610	-	272614	-
H	30.6	-	-	-	-	74073	-	74073
H	40.6	-	-	-	-	238910	-	238914

Standard Voltages: 24, 120, 240, 480 volts AC, 60 Hz (or 110, 220 volts AC, 50 Hz). 6, 12, 24, 120, 240 volts DC. Must be specified when ordering. Other voltages available when required.

Solenoid Enclosures

Standard: Red-Hat II - Watertight, Types 1, 2, 3, 3S, 4, and 4X; Red-Hat - Type I.
Optional: Red-Hat II - Explosionproof and Watertight, Types 3, 3S, 4, 4X, 6, 6P, 7, and 9; Red-Hat - Explosionproof and Watertight, Types 3, 4, 4X, 7, and 9.
 (To order, add prefix "EF" to catalog number, except Catalog Numbers 8210B57, 8210B58, and 8210B59. Valves not available with Explosionproof enclosures.)
 Note: Wattages 16.1 and 20.1 meet Type 7 Groups A, B, C, and D and Type 9 Groups E and F only.
 See *Optional Features Section* for other available options.

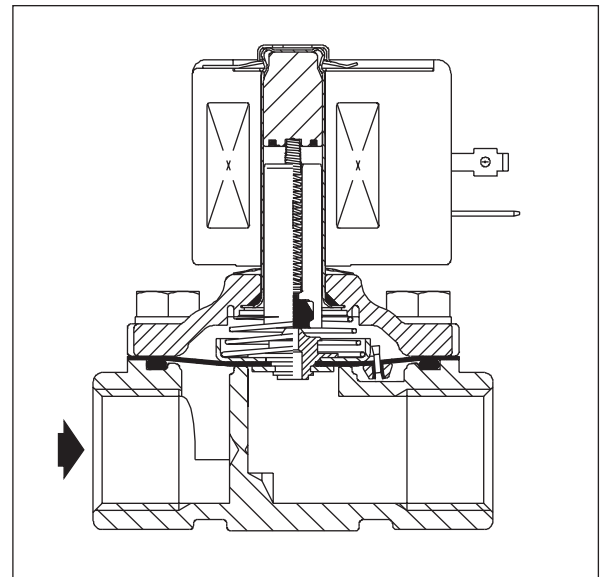
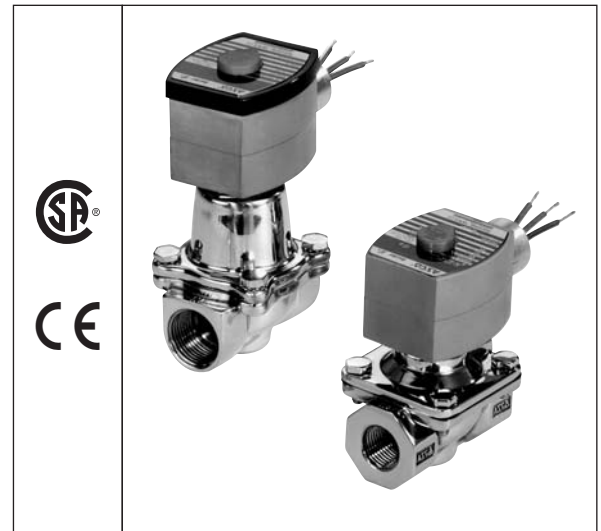

Nominal Ambient Temperature Ranges:

- Red-Hat II/
- Red-Hat AC: 32°F to 125°F (0°C to 52°C)
- Red-Hat II DC: 32°F to 104°F (0°C to 40°C)
- Red-Hat DC: 32°F to 77°F (0°C to 25°C)
 (104°F/40°C occasionally)

Refer to Engineering Section for details.

Approvals:

CSA certified. Red-Hat II meets applicable CE directives.
Refer to Engineering Section for details.

Specifications (English units)

Pipe Size (ins.)	Orifice Size (ins.)	Cv Flow Factor	Operating Pressure Differential (psi)							Max. Fluid Temp. °F		Brass Body			Stainless Steel Body			Watt Rating/Class of Coil Insulation ⑦	
			Min.	Max. AC			Max. DC			AC	DC	Catalog Number	Constr. Ref. No. ④	UL ⑤ Listing	Catalog Number	Constr. Ref. No. ④	UL ⑤ Listing	AC	DC
				Air-Inert Gas	Water	Light Oil @ 300 SSU	Air-Inert Gas	Water	Light Oil @ 300 SSU										
NORMALLY CLOSED (Closed when de-energized), NBR or PTFE ② Seating																			
3/8	3/8	1.5	①	150	125	-	40	40	-	180	150	8210G73 ③	1P	●	8210G36 ③	1P	●	6.1/F	11.6/F
3/8	5/8	3	0	150	150	-	40	40	-	180	150	8210G93	5D	○	-	-	-	10.1/F	11.6/F
3/8	5/8	3	5	200	150	135	125	100	100	180	150	8210G1	6D	○	-	-	-	6.1/F	11.6/F
3/8	5/8	3	5	300	300	300	-	-	-	175	-	8210G6	5D	○	-	-	-	17.1/F	-
1/2	7/16	2.2	①	150	125	-	40	40	-	180	150	8210G15 ③	2P	●	8210G37 ③	2P	●	6.1/F	11.6/F
1/2	5/8	4	0	150	150	-	40	40	-	180	150	8210G94	5D	○	-	-	-	10.1/F	11.6/F
1/2	5/8	4	0	150	150	125	40	40	-	175	150	-	-	-	8210G87	7D	●	17.1/F	11.6/F
1/2	5/8	4	5	200	150	135	125	100	100	180	150	8210G2	6D	○	-	-	-	6.1/F	11.6/F
1/2	5/8	4	5	300	300	300	-	-	-	175	-	8210G7	5D	○	-	-	-	17.1/F	-
1/2	5/8	4	5	-	300	-	-	300	-	180	125	8210G227	5D	○	-	-	-	17.1/F	40.6/H
3/4	5/8	4.5	0	150	150	125	40	40	-	175	150	-	-	-	8210G88	7D	●	17.1/F	11.6/F
3/4	3/4	5	5	125	125	125	100	90	75	180	150	8210G9	9D	○	-	-	-	6.1/F	11.6/F
3/4	3/4	5	0	150	150	-	40	40	-	180	150	8210G95	8D	○	-	-	-	10.1/F	11.6/F
3/4	3/4	6.5	5	250	150	100	125	125	125	180	150	8210G3	11D	○	-	-	-	6.1/F	11.6/F
3/4	3/4	6	0	-	-	-	200	180	180	-	77	8210B26 ② ‡	10P	-	-	-	-	-	30.6/H
3/4	3/4	6	0	350	300	200	-	-	-	200	-	8210G26 ② ‡	40P	●	-	-	-	16.1F	-
1	1	13	0	-	-	-	100	100	80	-	77	8210B54 ‡	31D	-	8210D89	15D	-	-	30.6/H
1	1	13	0	150	125	125	-	-	-	180	-	8210G54	41D	●	8210G89	45D	●	16.1/F	-
1	1	13	5	150	150	100	125	125	125	180	150	8210G4	12D	○	-	-	-	6.1/F	11.6/F
1	1	13.5	0	300	225	115	-	-	-	200	-	8210G27 ‡	42P	●	-	-	-	20.1/F	-
1	1	13.5	10	300	300	300	-	-	-	175	-	8210G78 ②	13P	-	-	-	-	17.1/F	-
1 1/4	1 1/8	15	0	-	-	-	100	100	80	-	77	8210B55 ‡	32D	-	-	-	-	-	30.6/H
1 1/4	1 1/8	15	0	150	125	125	-	-	-	180	-	8210G55	43D	●	-	-	-	16.1/F	-
1 1/4	1 1/8	15	5	150	150	100	125	125	125	180	150	8210G8	16D	○	-	-	-	6.1/F	11.6/F
1 1/2	1 1/4	22.5	0	-	-	-	100	100	80	-	77	8210B56 ‡	33D	-	-	-	-	-	30.6/H
1 1/2	1 1/4	22.5	0	150	125	125	-	-	-	180	-	8210G56	44D	●	-	-	-	16.1/F	-
1 1/2	1 1/4	22.5	5	150	150	100	125	125	125	180	150	8210G22	18D	●	-	-	-	6.1/F	11.6/F
2	1 3/4	43	5	150	125	90	50	50	50	180	150	8210G100	20P	●	-	-	-	6.1/F	11.6/F
2 1/2	1 3/4	45	5	150	125	90	50	50	50	180	150	8210G101	21P	●	-	-	-	6.1/F	11.6/F
NORMALLY OPEN (Open when de-energized), NBR Seating (PA Disc-Holder, except as noted)																			
3/8	5/8	3	0	150	150	125	125	125	80	180	150	8210G33	23D	●	-	-	-	10.1/F	11.6/F
3/8	5/8	3	5	250	200	200	250	200	200	180	180	8210G11 ⑧ ⑨	39D	●	-	-	-	10.1/F	11.6/F
1/2	5/8	4	0	150	150	125	125	125	80	180	150	8210G34	23D	●	-	-	-	10.1/F	11.6/F
1/2	5/8	3	0	150	150	100	125	125	80	180	150	-	-	-	8210G30	37D	●	10.1/F	11.6/F
1/2	5/8	4	5	250	200	200	250	200	200	180	180	8210G12 ⑧ ⑨	39D	●	-	-	-	10.1/F	11.6/F
3/4	3/4	5.5	0	150	150	125	125	125	80	180	150	8210G35	25D	●	-	-	-	10.1/F	11.6/F
3/4	5/8	3	0	150	150	100	125	125	80	180	150	-	-	-	8210G38	38D	●	10.1/F	11.6/F
3/4	3/4	6.5	5	-	-	-	250	200	200	-	180	8210C13	24D	●	-	-	-	-	16.8/F
3/4	3/4	6.5	5	250	200	200	-	-	-	180	-	8210G13	46D	●	-	-	-	16.1/F	-
1	1	13	0	125	125	125	-	-	-	180	-	8210B57 ⑥ ⑩	34D	●	-	-	-	20/F	-
1	1	13	5	-	-	-	125	125	125	-	180	8210D14	26D	●	-	-	-	-	16.8/F
1	1	13	5	150	150	125	-	-	-	180	-	8210G14	47D	●	-	-	-	16.1/F	-
1 1/4	1 1/8	15	0	125	125	125	-	-	-	180	-	8210B58 ⑥ ⑩	35D	●	-	-	-	20/F	-
1 1/4	1 1/8	15	5	-	-	-	125	125	125	-	180	8210D18	28D	●	-	-	-	-	16.8/F
1 1/4	1 1/8	15	5	150	150	125	-	-	-	180	-	8210G18	48D	●	-	-	-	16.1/F	-
1 1/2	1 1/4	22.5	0	125	125	125	-	-	-	180	-	8210B59 ⑥ ⑩	36D	●	-	-	-	20/F	-
1 1/2	1 1/4	22.5	5	-	-	-	125	125	125	-	180	8210D32	29D	●	-	-	-	-	16.8/F
1 1/2	1 1/4	22.5	5	150	150	125	-	-	-	180	-	8210G32	49D	●	-	-	-	16.1/F	-
2	1 3/4	43	5	-	-	-	125	125	125	-	150	8210I03	30P	●	-	-	-	-	16.8/F
2	1 3/4	43	5	125	125	125	-	-	-	180	-	8210G103	50P	●	-	-	-	16.1/F	-
2 1/2	1 3/4	45	5	-	-	-	125	125	125	-	150	8210I04	27P	●	-	-	-	-	16.8/F
2 1/2	1 3/4	45	5	125	125	125	-	-	-	180	-	8210G104	51P	●	-	-	-	16.1/F	-

Notes: ① 5 psi on Air; 1 psi on Water.
 ② Valve provided with PTFE main disc.
 ③ Valve includes Ultem (G.E. trademark) piston.
 ④ Letter "D" denotes diaphragm construction; "P" denotes piston construction.
 ⑤ ○ Safety Shutoff Valve; ● General Purpose Valve.
 Refer to Engineering Section (Approvals) for details.

⑥ Valves not available with Explosionproof enclosures.
 ⑦ On 50 hertz service, the watt rating for the 6.1/F solenoid is 8.1 watts.
 ⑧ AC construction also has PA seating.
 ⑨ No disc-holder.
 ⑩ Stainless Steel disc-holder.
 ‡ Must have solenoid mounted vertical and upright.

Specifications (Metric units)

Pipe Size (ins.)	Orifice Size (mm)	Kv Flow Factor (m3/h)	Operating Pressure Differential (bar)							Max. Fluid Temp. °C		Brass Body			Stainless Steel Body			AC	DC
			Max. AC				Max. DC			AC	DC	Catalog Number	Constr. Ref. No. ④	UL ⑤ Listing	Catalog Number	Constr. Ref. No. ④	UL ⑤ Listing		
			Min.	Air-Inert Gas	Water	Light Oil @ 300 SSU	Air-Inert Gas	Water	Light Oil @ 300 SSU										
NORMALLY CLOSED (Closed when de-energized), NBR or PTFE ② Seating																			
3/8	10	1.29	①	10	9	-	3	3	-	81	65	8210G73 ③	1P	●	8210G36 ③	1P	●	6.1/F	11.6/F
3/8	16	2.57	0	10	10	-	3	3	-	81	65	8210G93	5D	○	-	-	-	10.1/F	11.6/F
3/8	16	2.57	0.3	14	10	9	9	7	7	81	65	8210G1	6D	○	-	-	-	6.1/F	11.6/F
3/8	16	2.57	0.3	21	21	21	-	-	-	79	-	8210G6	5D	○	-	-	-	17.1/F	-
1/2	11	1.89	①	10	9	-	3	3	-	81	65	8210G15 ③	2P	●	8210G37 ③	2P	●	6.1/F	11.6/F
1/2	16	3.43	0	10	10	-	3	3	-	81	65	8210G94	5D	○	-	-	-	10.1/F	11.6/F
1/2	16	3.43	0	10	10	9	3	3	-	79	65	-	-	-	8210G87	7D	●	17.1/F	11.6/F
1/2	16	3.43	0.3	14	10	9	9	7	7	81	65	8210G2	6D	○	-	-	-	6.1/F	11.6/F
1/2	16	3.43	0.3	21	21	21	-	-	-	79	-	8210G7	5D	○	-	-	-	17.1/F	-
1/2	16	3.43	0.3	-	21	-	-	21	-	81	52	8210G227	5D	○	-	-	-	17.1/F	40.6H
3/4	16	3.86	0	10	10	9	3	3	-	79	65	-	-	-	8210G88	7D	●	17.1/F	11.6/F
3/4	19	4.29	0.3	9	9	9	7	6	5	81	65	8210G9	9D	○	-	-	-	6.1/F	11.6/F
3/4	19	4.29	0	10	10	-	3	3	-	81	65	8210G95	8D	○	-	-	-	10.1/F	11.6/F
3/4	19	5.57	0.3	17	10	7	9	9	9	81	65	8210G3	11D	○	-	-	-	6.1/F	11.6/F
3/4	19	5.14	0	-	-	-	14	12	12	-	25	8210B26 ② ‡	10P	-	-	-	-	-	30.6/H
3/4	19	5.14	0	24	21	14	-	-	-	92	-	8210G26 ② ‡	40P	●	-	-	-	16.1F	-
1	25	11.14	0	-	-	-	7	7	6	-	25	8210B54 ‡	31D	-	8210D89	15D	-	-	30.6/H
1	25	11.14	0	10	9	9	-	-	-	81	-	8210G54	41D	●	8210G89	45D	●	16.1/F	-
1	25	11.14	0.3	10	10	7	9	9	9	81	65	8210G4	12D	○	-	-	-	6.1/F	11.6/F
1	25	11.57	0	21	16	8	-	-	-	92	-	8210G27 ‡	42P	●	-	-	-	20.1/F	-
1	25	11.57	0.7	21	21	21	-	-	-	79	-	8210G78 ②	13P	-	-	-	-	17.1/F	-
1 1/4	29	12.86	0	-	-	-	7	7	6	-	25	8210B55 ‡	32D	-	-	-	-	-	30.6/H
1 1/4	29	12.86	0	10	9	9	-	-	-	81	-	8210G55	43D	●	-	-	-	16.1/F	-
1 1/4	29	12.86	0.3	10	10	7	9	9	9	81	65	8210G8	16D	○	-	-	-	6.1/F	11.6/F
1 1/2	32	19.29	0	-	-	-	7	7	6	-	25	8210B56 ‡	33D	-	-	-	-	-	30.6/H
1 1/2	32	19.29	0	10	9	9	-	-	-	81	-	8210G56	44D	●	-	-	-	16.1/F	-
1 1/2	32	19.29	0.3	10	10	7	9	9	9	81	65	8210G22	18D	●	-	-	-	6.1/F	11.6/F
2	44	36.86	0.3	10	9	6	3	3	3	81	65	8210G100	20P	●	-	-	-	6.1/F	11.6/F
2 1/2	44	38.57	0.3	10	9	6	3	3	3	81	65	8210G101	21P	●	-	-	-	6.1/F	11.6/F
NORMALLY OPEN (Open when de-energized), NBR Seating (PA Disc-Holder, except as noted)																			
3/8	16	2.57	0.0	10	10	9	9	9	6	81	65	8210G33	23D	●	-	-	-	10.1/F	11.6/F
3/8	16	2.57	0.3	17	14	14	17	14	14	81	81	8210G11 ⑧ ⑨	39D	●	-	-	-	10.1/F	11.6/F
1/2	16	3.43	0	10	10	9	9	9	6	81	65	8210G34	23D	●	-	-	-	10.1/F	11.6/F
1/2	16	2.57	0	10	10	7	9	9	6	81	65	-	-	-	8210G30	37D	●	10.1/F	11.6/F
1/2	16	3.43	0.3	17	14	14	17	14	14	81	81	8210G12 ⑧ ⑨	39D	●	-	-	-	10.1/F	11.6/F
3/4	19	4.71	0	10	10	9	9	9	6	81	65	8210G35	25D	●	-	-	-	10.1/F	11.6/F
3/4	16	2.57	0	10	10	7	9	9	6	81	65	-	-	-	8210G38	38D	●	10.1/F	11.6/F
3/4	19	5.57	0.3	-	-	-	17	14	14	-	81	8210C13	24D	●	-	-	-	-	16.8/F
3/4	19	5.57	0.3	17	14	14	-	-	-	81	-	8210G13	46D	●	-	-	-	16.1/F	-
1	25	11.14	0	9	9	9	-	-	-	81	-	8210B57 ⑥ ⑩	34D	●	-	-	-	20/F	-
1	25	11.14	0.3	-	-	-	9	9	9	-	81	8210D14	26D	●	-	-	-	-	16.8/F
1	25	11.14	0.3	10	10	9	-	-	-	81	-	8210G14	47D	●	-	-	-	16.1/F	-
1 1/4	29	12.86	0	9	9	9	-	-	-	81	-	8210B58 ⑥ ⑩	35D	●	-	-	-	20/F	-
1 1/4	29	12.86	0.3	-	-	-	9	9	9	-	81	8210D18	28D	●	-	-	-	-	16.8/F
1 1/4	29	12.86	0.3	10	10	9	-	-	-	81	-	8210G18	48D	●	-	-	-	16.1/F	-
1 1/2	32	19.29	0	9	9	9	-	-	-	81	-	8210B59 ⑥ ⑩	36D	●	-	-	-	20/F	-
1 1/2	32	19.29	0.3	-	-	-	9	9	9	-	81	8210D32	29D	●	-	-	-	-	16.8/F
1 1/2	32	19.29	0.3	10	10	9	-	-	-	81	-	8210G32	49D	●	-	-	-	16.1/F	-
2	44	36.86	0.3	-	-	-	9	9	9	-	65	8210I03	30P	●	-	-	-	-	16.8/F
2	44	36.86	0.3	9	9	9	-	-	-	81	-	8210G103	50P	●	-	-	-	16.1/F	-
2 1/2	44	38.57	0.3	-	-	-	9	9	9	-	65	8210I04	27P	●	-	-	-	-	16.8/F
2 1/2	44	38.57	0.3	9	9	9	-	-	-	81	-	8210G104	51P	●	-	-	-	16.1/F	-

Notes: ① 0.3 bar on Air; 0.0 bar on Water.
 ② Valve provided with PTFE main disc.
 ③ Valve includes Ultem (G.E. trademark) piston.
 ④ Letter "D" denotes diaphragm construction; "P" denotes piston construction.
 ⑤ ○ Safety Shutoff Valve; ● General Purpose Valve.
 Refer to Engineering Section (Approvals) for details.
 ⑥ Valves not available with Explosionproof enclosures.
 ⑦ On 50 hertz service, the watt rating for the 6.1/F solenoid is 8.1 watts.
 ⑧ AC construction also has PA seating.
 ⑨ No disc-holder.
 ⑩ Stainless Steel disc-holder.
 ‡ Must have solenoid mounted vertical and upright.

Dimensions: inches (mm)

Constr. Ref. No.		H	K	L	P	W
1*	ins.	3.85	3.00	1.91	3.41	1.69
	mm	98	76	49	87	43
2*	ins.	4.17	3.25	2.28	3.63	1.69
	mm	106	83	58	92	43
13	ins.	4.44	3.22	3.75	4.19	5.81
	mm	113	82	95	106	147
5	ins.	3.84	2.31	2.75	3.28	2.28
	mm	98	59	70	83	58
6*	ins.	3.38	1.94	2.75	2.80	2.28
	mm	86	49	70	71	58
7	ins.	4.19	2.50	2.81	3.47	2.39
	mm	106	64	71	88	61
8	ins.	4.13	2.47	2.81	3.44	2.29
	mm	105	63	71	87	58
9*	ins.	3.66	2.10	2.81	2.96	2.28
	mm	93	53	71	75	58
10*Ⓞ	ins.	5.25	X	2.81	4.59	2.31
	mm	133	X	71	117	59
11*	ins.	4.16	2.66	3.84	3.52	2.75
	mm	106	68	98	89	70
12	ins.	5.64	3.15	3.75	4.01	3.36
	mm	143	80	95	102	85
15*	ins.	5.34	X	3.75	4.47	3.84
	mm	136	X	95	114	98
16	ins.	5.64	3.15	3.66	4.01	3.56
	mm	143	80	93	102	90
18	ins.	6.11	3.30	4.38	4.16	3.92
	mm	155	84	111	106	100
20*	ins.	7.33	3.71	5.06	4.57	4.87
	mm	186	94	129	116	124
21*	ins.	7.33	3.71	5.50	4.57	4.87
	mm	186	94	140	116	124
23	ins.	4.35	2.65	2.75	3.79	2.28
	mm	110	67	70	96	58
24	ins.	5.06	X	3.78	4.44	2.75
	mm	129	X	96	113	70
25	ins.	4.64	2.81	2.81	3.94	2.28
	mm	118	71	71	100	58
26	ins.	6.53	X	3.75	4.91	3.19
	mm	166	X	95	125	81
27	ins.	8.22	X	5.50	5.47	4.87
	mm	209	X	140	139	124
28	ins.	6.53	X	3.66	4.91	3.19
	mm	166	X	93	125	81
29	ins.	7.03	X	4.38	5.06	4.40
	mm	179	X	111	129	112

Ⓞ Valves must be mounted with solenoid vertical and upright.
* DC dimensions slightly larger.

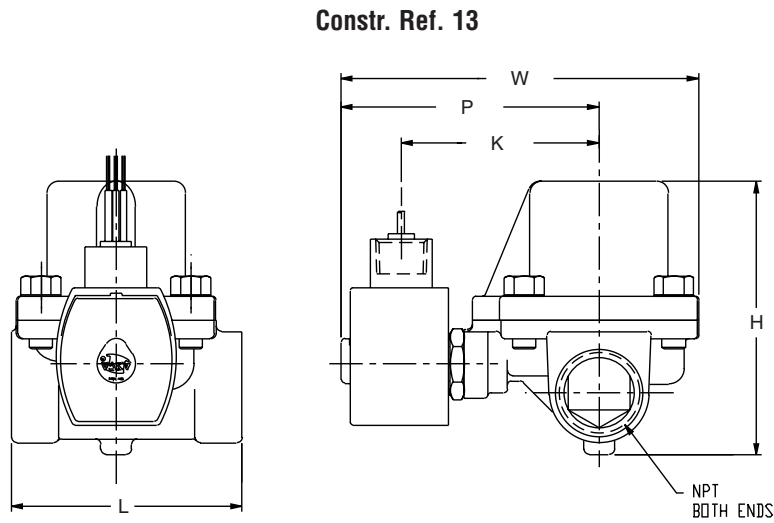
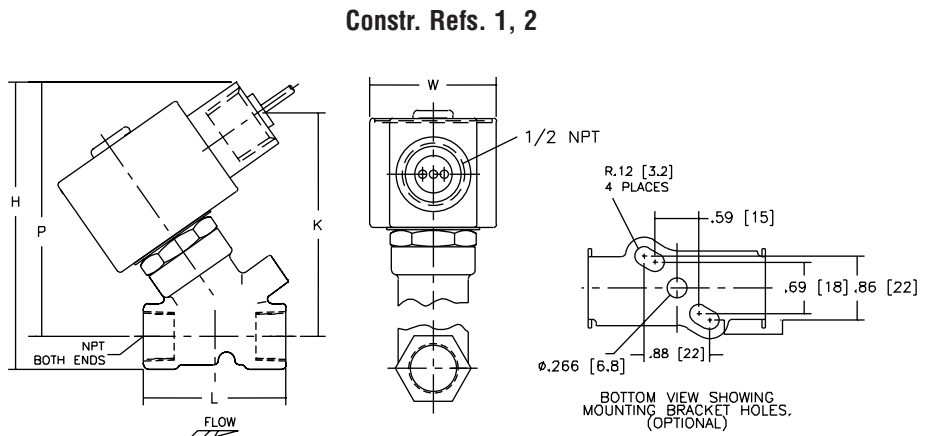
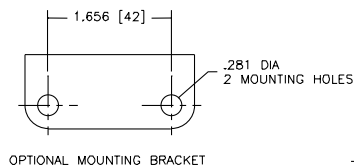

Constr. Refs. 5-9, 11, 20, 21, 23, 25, 37, 38

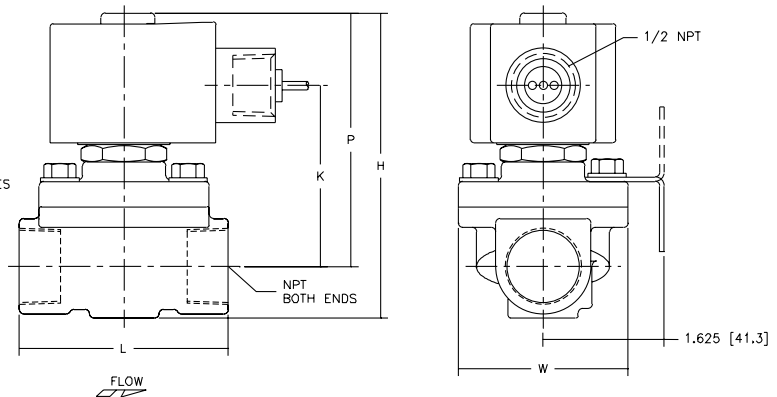

Dimensions: inches (mm)

Constr. Ref. No.		H	K	L	P	W
30	ins.	8.22	X	5.06	5.47	4.87
	mm	209	X	129	139	124
31	ins.	5.25	X	3.75	4.44	3.25
	mm	133	X	95	113	83
32	ins.	5.69	X	3.66	4.69	3.25
	mm	145	X	93	119	83
33	ins.	6.06	X	4.38	4.94	3.91
	mm	154	X	111	125	99
34	ins.	6.91	X	3.75	6.09	3.25
	mm	176	X	95	155	83
35	ins.	7.34	X	3.66	6.34	3.25
	mm	186	X	93	161	83
36	ins.	7.66	X	4.38	6.56	3.91
	mm	195	X	111	167	99
37	ins.	4.61	2.75	2.81	3.89	2.39
	mm	117	70	71	99	61
38	ins.	4.61	2.75	2.81	3.89	2.39
	mm	117	70	71	99	61
39	ins.	5.42	2.31	2.75	4.86	3.80
	mm	138	59	70	123	97
40	ins.	5.20	3.29	2.81	4.50	2.28
	mm	132	83	71	114	58
41	ins.	5.13	3.10	3.75	4.32	3.25
	mm	130	79	95	110	83
42	ins.	6.43	4.40	3.93	5.62	3.25
	mm	163	112	100	143	83
43	ins.	5.57	3.35	3.66	4.57	3.25
	mm	142	85	93	116	83
44	ins.	5.90	3.57	4.38	4.79	3.91
	mm	150	91	111	122	99
45	ins.	5.26	3.17	3.75	4.38	3.84
	mm	134	81	95	111	98
46	ins.	4.95	3.10	3.84	4.31	2.75
	mm	126	79	98	110	70
47	ins.	6.43	3.59	3.75	4.81	3.52
	mm	163	91	95	122	90
48	ins.	6.43	3.59	3.66	4.81	3.73
	mm	163	91	93	122	95
49	ins.	6.91	3.75	4.38	4.96	4.40
	mm	176	95	111	126	112
50	ins.	8.13	4.15	5.06	5.37	4.87
	mm	207	105	129	136	124
51	ins.	8.13	4.15	5.50	5.37	5.18
	mm	207	105	140	136	132

IMPORTANT: Valves may be mounted in any position, except as noted in specifications table.

Constr. Refs. 10, 15, 24, 26-36

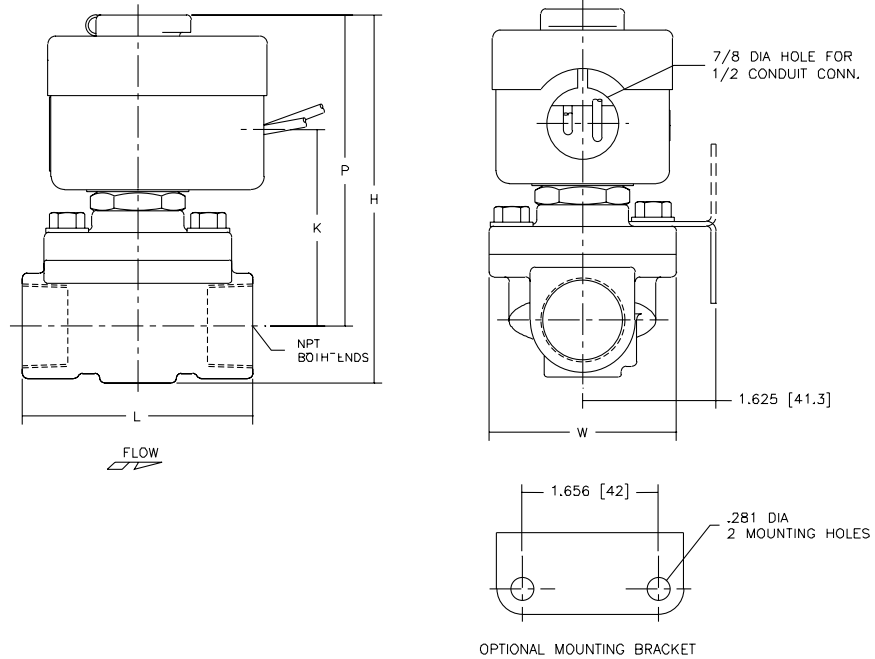

Constr. Refs. 12, 16, 18

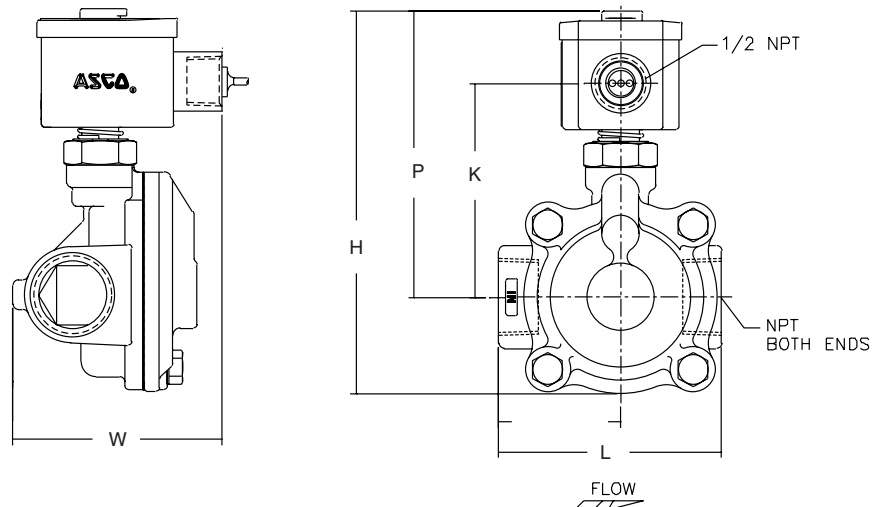

Note: Valve must be mounted with solenoid vertical and upright.

Dimensions: inches (mm)

Constr. Refs. 39

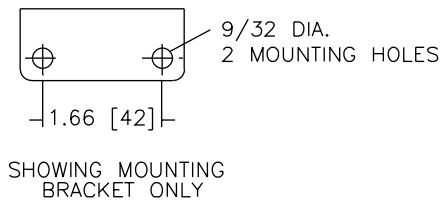
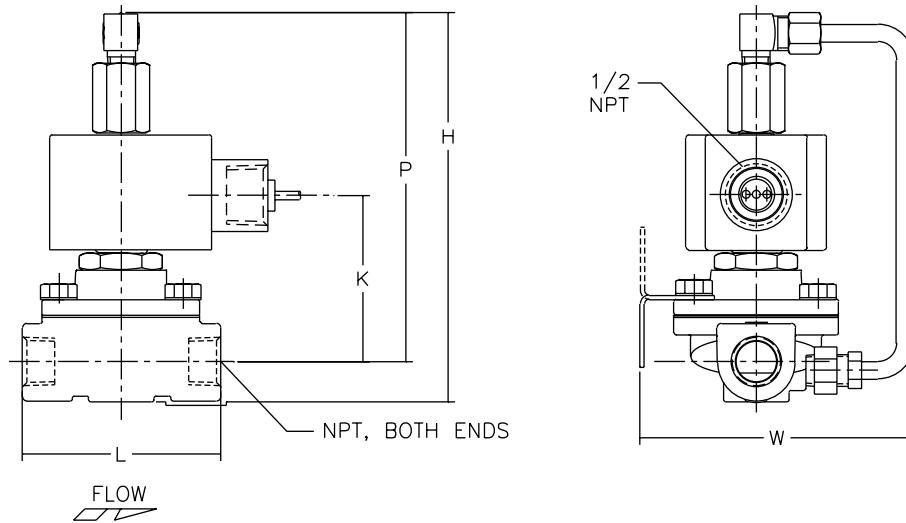

Constr. Refs. 40-51

