

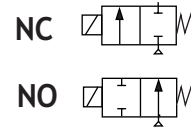

Direct Acting
General Service Solenoid Valves
 Brass or Stainless Steel Bodies
 1/8" to 3/8" NPT



2/2
 SERIES
8262
8263

Features

- Reliable, proven design with high flows.
- Small poppet valves for tight shutoff.
- Wide range of elastomers for specialty service.
- Mountable in any position.
- Brass and Stainless Steel body constructions.

Construction

Valve Parts in Contact with Fluids		
Body	Brass	303/304 Stainless Steel
Seals and Discs	NBR or Cast UR	
Core Tube	305 Stainless Steel	
Core and Plugnut	430F Stainless Steel	
Springs	302 Stainless Steel	
Shading Coil	Copper	Silver
Stem	PA (Normally Open)	
Note: All 1/8" NPT Normally Open valves contain CA. All 1/4" NPT Normally Open valves contain PA.		

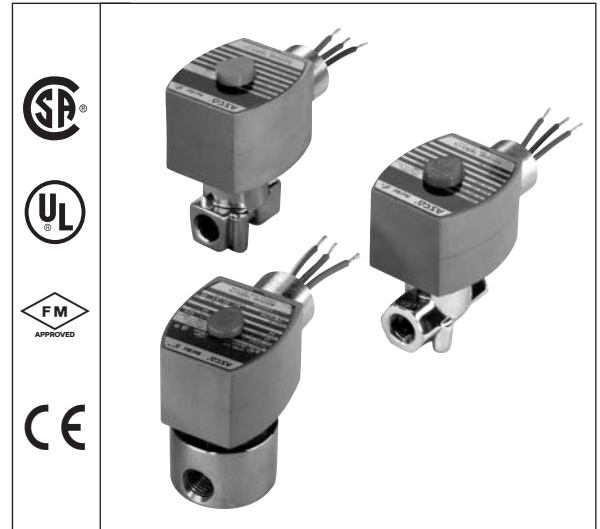

Electrical

Standard Coil and Class of Insulation	Watt Rating and Power Consumption				Spare Coil Part No.			
	DC Watts	AC			General Purpose		Explosionproof	
		Watts	VA Holding	VA Inrush	AC	DC	AC	DC
F	10.6	6.1	16	30	238210	238310	238214	238314
F	11.6	10.1	25	50	238610	238710	238614	238714
F	22.6	17.1	40	70	238610	238710	238614	238714

Standard Voltages 24, 120, 240, 480 volts AC, 60 Hz (or 110, 220 volts AC, 50 Hz).
 6, 12, 24, 120, 240 volts DC. Must be specified when ordering. Other voltages available when required.

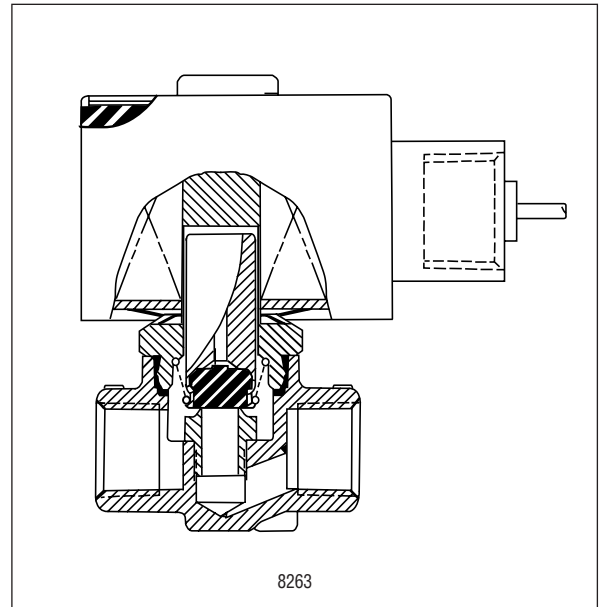

Solenoid Enclosures

Standard: Watertight, Types 1, 2, 3, 3S, 4, and 4X.
Optional: Explosionproof and Watertight, Types 3, 3S, 4, 4X, 6, 6P, 7, and 9.
 (To order, add prefix "EF" to catalog number)
 See *Optional Features Section* for other available options.

Nominal Ambient Temperature Ranges:

AC: 32°F to 125°F (0°C to 52°C)
 DC: 32°F to 104°F (0°C to 40°C)
 Refer to *Engineering Section* for details.

Approvals:

CSA certified. UL listed, as indicated. Most Normally Closed Valves FM approved. Meets applicable CE directives.
 Refer to *Engineering Section* for details.

Specifications (English units)

Pipe Size (ins.)	Orifice Size (ins.)	Cv Flow Factor	Operating Pressure Differential (psi)						Max. Fluid Temp. °F		Brass Body			Stainless Steel Body			Watt Rating/ Class of Coil Insulation ②	
			Max. AC			Max. DC					Catalog Number	Constr. Ref. No.	UL ③ Listing	Catalog Number	Constr. Ref. No.	UL ③ Listing		
			Air-Inert Gas	Water	Lt. Oil @ 300 SSU	Air-Inert Gas	Water	Lt. Oil @ 300 SSU	AC	DC							AC	DC
NORMALLY CLOSED (Closed when de-energized), NBR Disc																		
1/8	3/64	.06	750	750	530	650	640	550	180	120	8262G1	1	○	8262G12	1	○	6.1/F	10.6/F
1/8	3/32	.20	275	290	130	150	140	145	180	120	8262G14	1	○	8262G15	1	○	6.1/F	10.6/F
1/8	1/8	.34	155	180	140	80	80	80	180	120	8262G2	1	○	8262G6	1	○	6.1/F	10.6/F
1/4	3/64	.06	750	750	500	500	500	500	180	120	8262G19	16	○	8262G80	11	○	6.1/F	10.6/F
1/4	3/64	.06	1500	1500	1100	475	475	450	140	140	8262G200	17	●	-	-	-	10.1/F	11.6/F
1/4	3/64	.06	2200	2000	1100	-	-	-	140	140	-	-	-	8262G214	12	●	10.1/F	-
1/4	3/32	.17	360	340	160	150	125	125	180	120	8262G20	16	○	8262G86	11	○	6.1/F	10.6/F
1/4	1/8	.35	140	165	90	65	60	60	180	120	8262G22	16	○	8262G7	11	○	6.1/F	10.6/F
1/4	1/8	.35	300	300	200	75	70	70	180	150	8262G232	17	○	-	-	-	10.1/F	11.6/F
1/4	5/32	.50	180	200	145	40	40	45	180	150	8262G202	4	○	8262G220	12	○	10.1/F	11.6/F
1/4	7/32	.72	90	100	100	25	25	25	180	150	8262G208	4	○	8262G226	12	○	10.1/F	11.6/F
1/4	7/32	.85	40	50	40	17	20	21	180	120	8262G13	2	○	8262G36	11	○	6.1/F	10.6/F
1/4	9/32	.88	60	75	60	18	15	18	180	150	8262G210	4	○	-	-	-	10.1/F	11.6/F
1/4	9/32	.88	90	100	90	25	20	22	180	150	8262G212	6	○	8262G230	13	○	17.1/F	22.6/F
1/4	9/32	.96	27	36	28	15	16	16	180	120	8262G90	2	○	8262G38	11	○	6.1/F	10.6/F
3/8	1/8	.35	160	150	90	65	60	60	180	120	8263G2	3	○	8263G330	3	○	6.1/F	10.6/F
3/8	5/32	.52	100	100	100	35	35	35	180	150	8263G200	5	○	8263G331	5	○	10.1/F	11.6/F
3/8	7/32	.72	100	100	100	25	25	25	180	150	8263G206	5	○	8263G332	5	○	17.1/F	11.6/F
3/8	9/32	.85	100	100	70	-	-	-	180	—	8263G210	7	○	8263G333	7	○	17.1/F	-
NORMALLY OPEN (Open when de-energized), NBR Disc (except where noted)																		
1/8	1/16	.09	500	300	225	400	250	150	180	120	8262G91	8	●	8262G92	8	●	6.1/F	10.6/F
1/8	3/32	.15	275	200	150	190	110	110	180	120	8262G93	8	●	8262G94	8	●	6.1/F	10.6/F
1/8	1/8	.21	125	100	85	80	60	50	180	120	8262G31	8	●	8262G35	8	●	6.1/F	10.6/F
1/4	3/64	.06	750	700	700	500	500	500	140	140	8262G260 ①	9	●	8262G130 ①	14	●	10.1/F	11.6/F
1/4	3/32	.17	300	250	230	200	150	125	140	140	8262G261 ①	9	●	8262G134 ①	14	●	10.1/F	11.6/F
1/4	1/8	.35	130	110	100	80	60	60	180	150	8262G262	9	●	8262G138	14	●	10.1/F	11.6/F
1/4	5/32	.49	85	75	60	45	30	30	180	150	8262G263	4	●	8262G142	14	●	10.1/F	11.6/F
1/4	7/32	.83	45	45	40	25	20	20	180	150	8262G264	4	●	8262G148	14	●	10.1/F	11.6/F
1/4	9/32	.96	30	25	20	15	15	15	180	150	8262G265	4	●	8262G152	14	●	10.1/F	11.6/F
Notes: ① Cast UR disc supplied as standard. ② On 50 hertz service, the rating for the 6.1/F solenoid is 8.1 watts. ③ ○ Safety Shutoff Valve; ● General Purpose Valve. Refer to Engineering Section (Approvals) for details.																		

Specifications (Metric units)

Pipe Size (ins.)	Orifice Size (mm)	Kv Flow Factor (m3/h)	Operating Pressure Differential (bar)						Max. Fluid Temp. °C		Brass Body			Stainless Steel Body			Watt Rating/ Class of Coil Insulation ②	
			Max. AC			Max. DC			AC	DC	Catalog Number	Constr. Ref. No.	UL ③	Catalog Number	Constr. Ref. No.	UL ③	AC	DC
			Air-Inert Gas	Water	Lt. Oil @ 300 SSU	Air-Inert Gas	Water	Lt. Oil @ 300 SSU										
NORMALLY CLOSED (Closed when de-energized), NBR Disc																		
1/8	1.2	.05	52	52	37	45	44	38	81	48	8262G1	1	○	8262G12	1	○	6.1/F	10.6/F
1/8	2.4	.17	19	20	9	10	10	10	81	48	8262G14	1	○	8262G15	1	○	6.1/F	10.6/F
1/8	3.2	.29	11	12	10	6	6	6	81	48	8262G2	1	○	8262G6	1	○	6.1/F	10.6/F
1/4	1.2	.05	52	52	34	34	34	34	81	48	8262G19	16	○	8262G80	11	○	6.1/F	10.6/F
1/4	1.2	.05	103	103	76	33	33	31	60	60	8262G200	17	●	-	-	-	10.1/F	11.6/F
1/4	1.2	.05	152	138	76	-	-	-	60	60	-	-	-	8262G214	12	●	10.1/F	-
1/4	2.4	.15	25	23	11	10	9	9	81	48	8262G20	16	○	8262G86	11	○	6.1/F	10.6/F
1/4	3.2	.30	10	11	6	4	4	4	81	48	8262G22	16	○	8262G7	11	○	6.1/F	10.6/F
1/4	3.2	.30	21	21	14	5	5	5	81	65	8262G232	17	○	-	-	-	10.1/F	11.6/F
1/4	4.0	.43	12	14	10	3	3	3	81	65	8262G202	4	○	8262G220	12	○	10.1/F	11.6/F
1/4	5.6	.62	6	7	7	2	2	2	81	65	8262G208	4	○	8262G226	12	○	10.1/F	11.6/F
1/4	5.6	.73	3	3	3	1	1	1	81	48	8262G13	2	○	8262G36	11	○	6.1/F	10.6/F
1/4	7.1	.75	4	5	4	1	1	1	81	65	8262G210	4	○	-	-	-	10.1/F	11.6/F
1/4	7.1	.75	6	7	6	2	1	2	81	65	8262G212	6	○	8262G230	13	○	17.1/F	22.6/F
1/4	7.1	.82	2	2	2	1	1	1	81	48	8262G90	2	○	8262G38	11	○	6.1/F	10.6/F
3/8	3.3	.30	11	10	6	4	4	4	81	48	8263G2	3	○	8263G330	3	○	6.1/F	10.6/F
3/8	4.0	.45	7	7	7	2	2	2	81	65	8263G200	5	○	8263G331	5	○	10.1/F	11.6/F
3/8	5.6	.62	7	7	7	2	2	2	81	65	8263G206	5	○	8263G332	5	○	17.1/F	11.6/F
3/8	7.1	.73	7	7	5	-	-	-	81	-	8263G210	7	○	8263G333	7	○	17.1/F	-
NORMALLY OPEN (Open when de-energized), NBR Disc (except where noted)																		
1/8	1.6	.08	34	21	16	28	17	10	81	48	8262G91	8	●	8262G92	8	●	6.1/F	10.6/F
1/8	2.4	.13	19	14	10	13	8	8	81	48	8262G93	8	●	8262G94	8	●	6.1/F	10.6/F
1/8	3.2	.18	9	7	6	6	4	3	81	48	8262G31	8	●	8262G35	8	●	6.1/F	10.6/F
1/4	1.2	.05	52	48	48	34	34	34	59	59	8262G260 ①	9	●	8262G130 ①	14	●	10.1/F	11.6/F
1/4	2.4	.15	21	17	16	14	10	9	59	59	8262G261 ①	9	●	8262G134 ①	14	●	10.1/F	11.6/F
1/4	3.2	.30	9	8	7	6	4	4	81	65	8262G262	9	●	8262G138	14	●	10.1/F	11.6/F
1/4	4.0	.42	6	5	4	3	2	2	81	65	8262G263	4	●	8262G142	14	●	10.1/F	11.6/F
1/4	5.6	.71	3	3	3	2	1	1	81	65	8262G264	4	●	8262G148	14	●	10.1/F	11.6/F
1/4	7.1	.82	2	2	1	1	1	1	81	65	8262G265	4	●	8262G152	14	●	10.1/F	11.6/F
Notes: ① Cast UR disc supplied as standard. ② On 50 Hertz service, the rating for the 6.1/F solenoid is 8.1 watts. ③ ○ Safety Shutoff Valve; ● General Purpose Valve. Refer to Engineering Section (Approvals) for details.																		

Dimensions: inches (mm)

Constr. Ref. No.		H	K	L	P	W
1	ins.	2.52	1.30	1.19	2.16	1.69
	mm	64	33	30	55	43
2	ins.	2.98	1.71	1.56	2.57	1.69
	mm	76	43	40	65	43
3	ins.	3.07	1.63	1.88	2.49	1.69
	mm	78	41	48	63	43
4	ins.	3.20	1.78	1.56	2.79	1.95
	mm	81	45	40	71	50
5	ins.	3.25	1.70	2.00	2.77	1.95
	mm	83	43	51	70	50
6	ins.	3.16	1.78	1.56	2.75	1.95
	mm	80	45	40	70	50
7	ins.	3.25	1.70	2.00	2.67	1.95
	mm	83	43	51	68	50
8	ins.	3.15	1.32	1.19	2.18	1.69
	mm	80	34	30	55	43
9	ins.	3.23	1.67	1.25	2.81	1.95
	mm	82	42	32	71	50
11	ins.	2.94	1.71	1.56	2.57	1.69
	mm	75	43	40	65	43
12	ins.	3.12	1.78	1.56	2.75	1.95
	mm	79	45	40	70	50
13	ins.	3.12	1.78	1.56	2.75	1.95
	mm	79	45	40	70	50
14	ins.	3.16	1.65	1.56	2.79	1.95
	mm	80	42	40	71	50
16	ins.	3.01	1.73	1.25	2.59	1.69
	mm	76	44	32	66	43
17	ins.	3.19	1.80	1.25	2.77	1.95
	mm	81	46	32	70	50

IMPORTANT: Valves may be mounted in any position.

Constr. Refs. 1

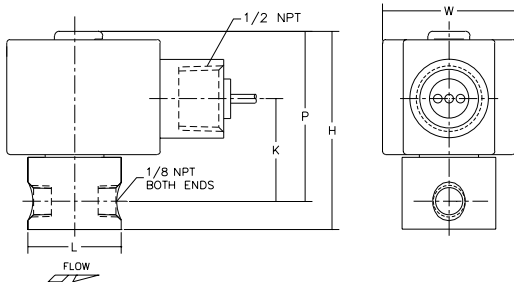

Constr. Refs. 2, 4, 6, 9

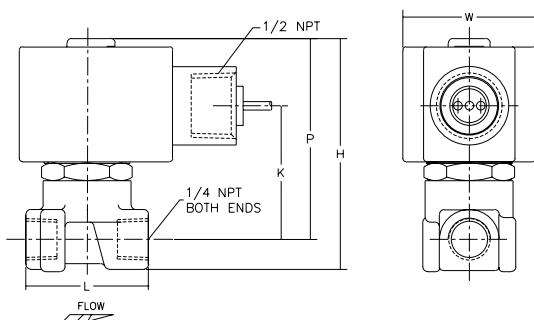

Constr. Refs. 8

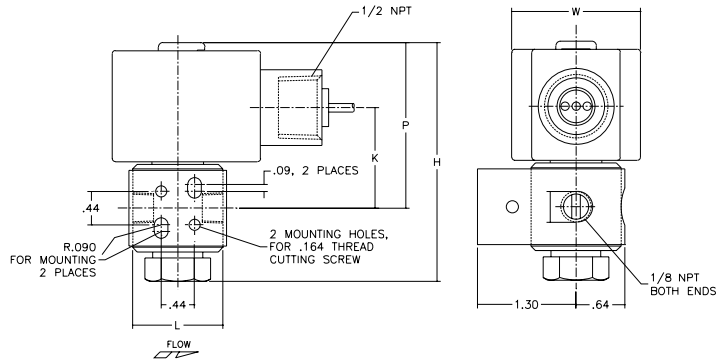

Constr. Refs. 3, 5, 7

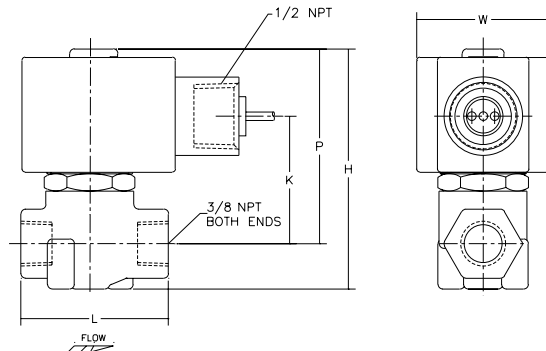

Constr. Refs. 11-14, 16, 17

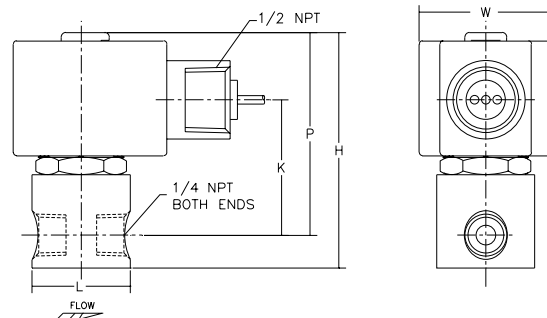

Mounting Details

MOUNTING HOLES IN VALVE BODY
BRASS-CONSTR. REFS. 3, 5, 7

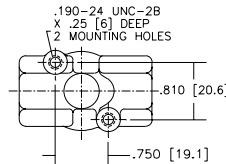

CONSTR. REF. 9, 16, 17



CONSTR. REF. 1 (BRASS)

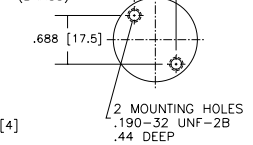

MOUNTING BRACKET
CONSTR. REFS. BRASS: 2, 4, 6, 9, 16, 17
ST. ST.: 1, 11-14

