

Features

- “LT” suffix valves are built to control cryogenic fluids, including liquid oxygen (-297°F/-181°C), liquid argon (-303°F/-184°C), and liquid nitrogen (-320°F/-194°C).
- All suffix “LT” valves are degreased, cleaned, tested free of moisture, and black light tested for hydrocarbons.
- Liquid CO₂ valves are suitable for remote mounting or for direct mounting to the refrigerated component by using four-hole bracket, provided.

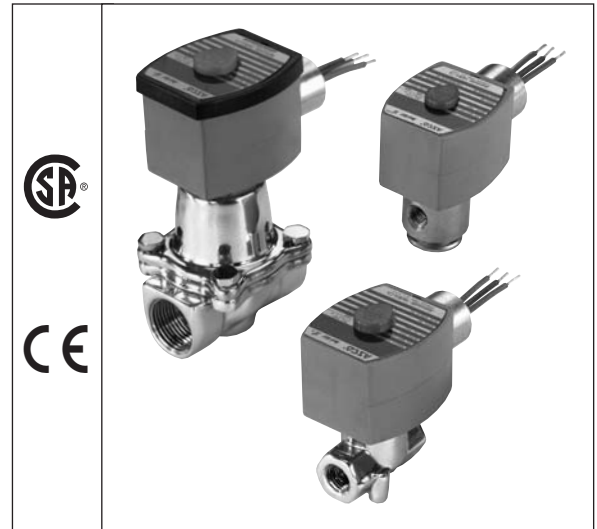

Construction

Valve Parts in Contact with Fluids	
Body: Cryogenic Valves	Brass
Body: LCO₂ Valves	Nickel-Plated Brass
Seals	PTFE and/or Lead-Free Copper/UR
Disc	PTFE/UR (8264 only)
Core and Plugnut	430F Stainless Steel or 49 FM Alloy
Core Spring	302 Stainless Steel
Shading Coil	Copper
Seats	Stainless Steel (8264 Series)

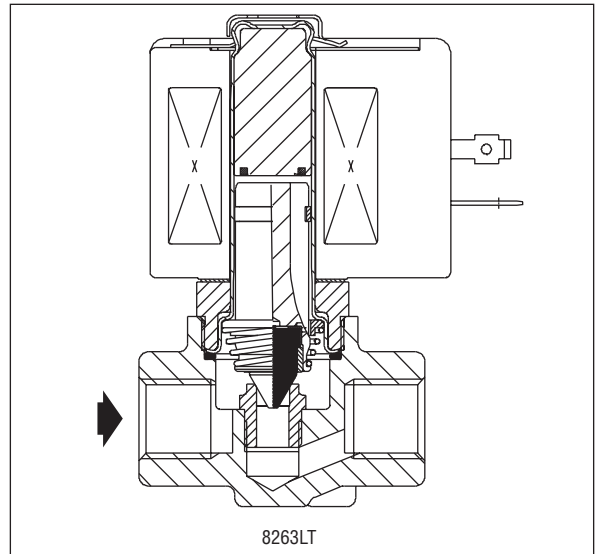

Electrical

Standard Coil and Class of Insulation	Watt Rating and Power Consumption				Spare Coil Part No.			
	DC Watts	AC			General Purpose		Explosionproof	
		Watts	VA Holding	VA Inrush	AC	DC	AC	DC
F	11.6	12.1	23	47	238610	238710	238614	238714
F	18.6	13.8	27	43	238210	238310	238214	238314
F	-	17.1	34	64	238610	-	238614	-
H	40.6	17.1	34	64	238810	238910	238814	238914

Standard Voltages: 24, 120, 240, 480 volts AC, 60 Hz. 6, 12, 24, 120, 240 volts DC. Must be specified when ordering. Other voltages are available when required.

Solenoid Enclosures

Standard: Watertight, Types 1, 2, 3, 3S, 4, and 4X.
Optional: Explosionproof and Watertight, Types 3, 3S, 4, 4X, 6, 6P, 7, and 9.
 (To order, add prefix “EF” to catalog number.)
 See *Optional Features Section* for other available options.

Nominal Fluid Temperature Ranges:

AC Cryogenic Valves: -320°F to 150°F (-196°C to 66°C)
 DC Cryogenic Valves: -320°F to 120°F (-196°C to 49°C)
 All Liquid CO₂ Valves: -75°F to 120°F (-59°C to 49°C)
 Refer to *Engineering Section* for details.

Nominal Ambient Temperature Ranges:

AC Construction: 32°F to 125°F (0°C to 52°C)
 DC Construction: 32°F to 104°F (0°C to 40°C)
 Refer to *Engineering Section* for details.

Approvals:

CSA certified. Meets applicable CE directives.
 Refer to *Engineering Section* for details.

Specifications (English units)

Pipe Size (ins.)	Orifice Size (ins.)	Cv Flow Factor	Operating Pressure Differential			Catalog Number	Constr. Ref. No.	Watt Rating/ Class of Coil Insulation	
			Min.	Max.				AC	DC
				AC	DC				
CRYOGENIC SERVICE - NORMALLY CLOSED (Closed when de-energized)									
1/8	1/8	.35	0	130	75	8263G240LT	2	12.1/F	11.6/F
1/4	1/8	.35	0	130	-	8262G22LT	1	12.1/F	—
1/4	7/32	.56	0	100	30	8263G205LT	2	17.1/F	11.6/F
1/4	9/32	.70	0	40	18	8263G209LT	2	12.1/F	11.6/F
3/8	1/8	.35	0	130	75	8263G232LT	2	12.1/F	11.6/F
3/8	7/32	.56	0	100	30	8263G206LT	3	17.1/F	11.6/F
3/8	9/32	.70	0	40	18	8263G210LT	3	12.1/F	11.6/F
1/2	5/8	3.8	0	90	50	8222G2LT	4	17.1/H	40.6/H
3/4	3/4	5.8	0	90	50	8222G3LT	4	17.1/H	40.6/H
1	1	13.5	5	200	100	8210G78LT	5	17.1/F	40.6/H
1 1/4	1 1/8	15	5	200	100	8210G80LT	6	17.1/F	40.6/H
1 1/2	1 1/4	22.5	5	200	100	8210G82LT	7	17.1/F	40.6/H
LIQUID CO₂ SERVICE - NORMALLY CLOSED (Closed when de-energized)									
1/8	3/64	.06	0	1000	1000	8264G9 ①	8	13.8/F	18.6/F
1/8	3/32	.20	0	300	300	8264G10 ①	8	13.8/F	18.6/F

Notes: ① Must use tubing with an I.D. no larger than the outlet port orifice to locate the refrigeration point downstream and to prevent freezing of the CO₂ inside the valve.

Specifications (Metric units)

Pipe Size (ins.)	Orifice Size (ins.)	Kv Flow Factor (m ³ /h)	Operating Pressure Differential (bar)			Catalog Number	Constr. Ref. No.	Watt Rating/ Class of Coil Insulation	
			Min.	Max.				AC	DC
				AC	DC				
CRYOGENIC SERVICE - NORMALLY CLOSED (Closed when de-energized)									
1/8	3	.35	0	9	5	8263G240LT	2	12.1/F	11.6/F
1/4	3	.35	0	9	-	8262G22LT	1	12.1/F	—
1/4	6	.56	0	7	2	8263G205LT	2	17.1/F	11.6/F
1/4	7	.70	0	3	1	8263G209LT	2	12.1/F	11.6/F
3/8	3	.35	0	9	5	8263G232LT	2	12.1/F	11.6/F
3/8	6	.56	0	7	2	8263G206LT	3	17.1/F	11.6/F
3/8	7	.70	0	3	1	8263G210LT	3	12.1/F	11.6/F
1/2	16	3.8	0	6	3	8222G2LT	4	17.1/H	40.6/H
3/4	19	5.8	0	6	3	8222G3LT	4	17.1/H	40.6/H
1	25	13.5	5	14	7	8210G78LT	5	17.1/F	40.6/H
1 1/4	29	15	5	14	7	8210G80LT	6	17.1/F	40.6/H
1 1/2	32	22.5	5	14	7	8210G82LT	7	17.1/F	40.6/H
LIQUID CO₂ SERVICE - NORMALLY CLOSED (Closed when de-energized)									
1/8	1	.05	0	69	69	8264G9 ①	8	13.8/F	18.6/F
1/8	2	.17	0	21	21	8264G10 ①	8	13.8/F	18.6/F

Notes: ① Must use tubing with an I.D. no larger than the outlet port orifice to locate the refrigeration point downstream and to prevent freezing of the CO₂ inside the valve.

Dimensions: inches (mm)

Constr. Ref. No.		H	K	L	P	W
1	ins.	3.19	1.80	Ø1.25	2.77	1.95
	mm	81	46	Ø32	70	50
2	ins.	3.25	1.70	1.88	2.67	1.95
	mm	83	43	48	68	50
3	ins.	3.25	1.70	2.00	2.67	1.95
	mm	83	43	51	68	50
4	ins.	4.67	3.15	2.75	4.11	1.95
	mm	119	80	70	104	50
5	ins.	5.82	3.22	3.75	4.19	4.44
	mm	148	82	95	106	113
6	ins.	5.82	3.22	3.66	4.19	4.86
	mm	148	82	93	106	123
7	ins.	6.29	3.37	4.38	4.34	5.81
	mm	160	86	111	110	148
8	ins.	2.82	1.27	Ø1.12	2.13	1.69
	mm	72	32	Ø28	54	43

IMPORTANT: Valves may be mounted in any position.

Constr. Ref. 1

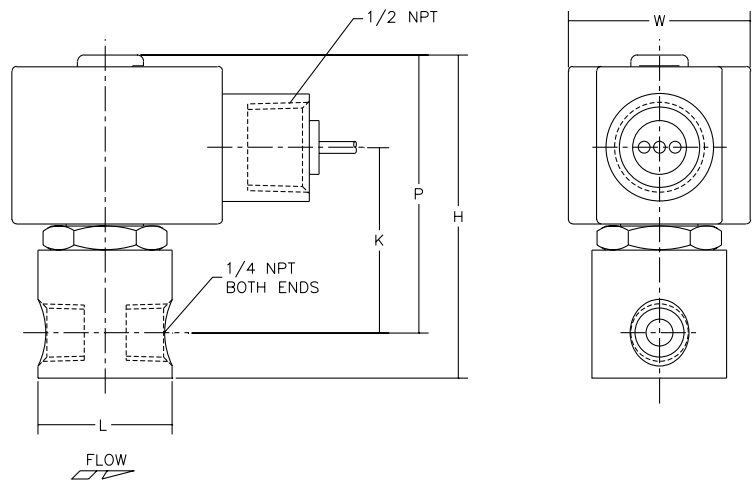

Constr. Ref. 2, 3

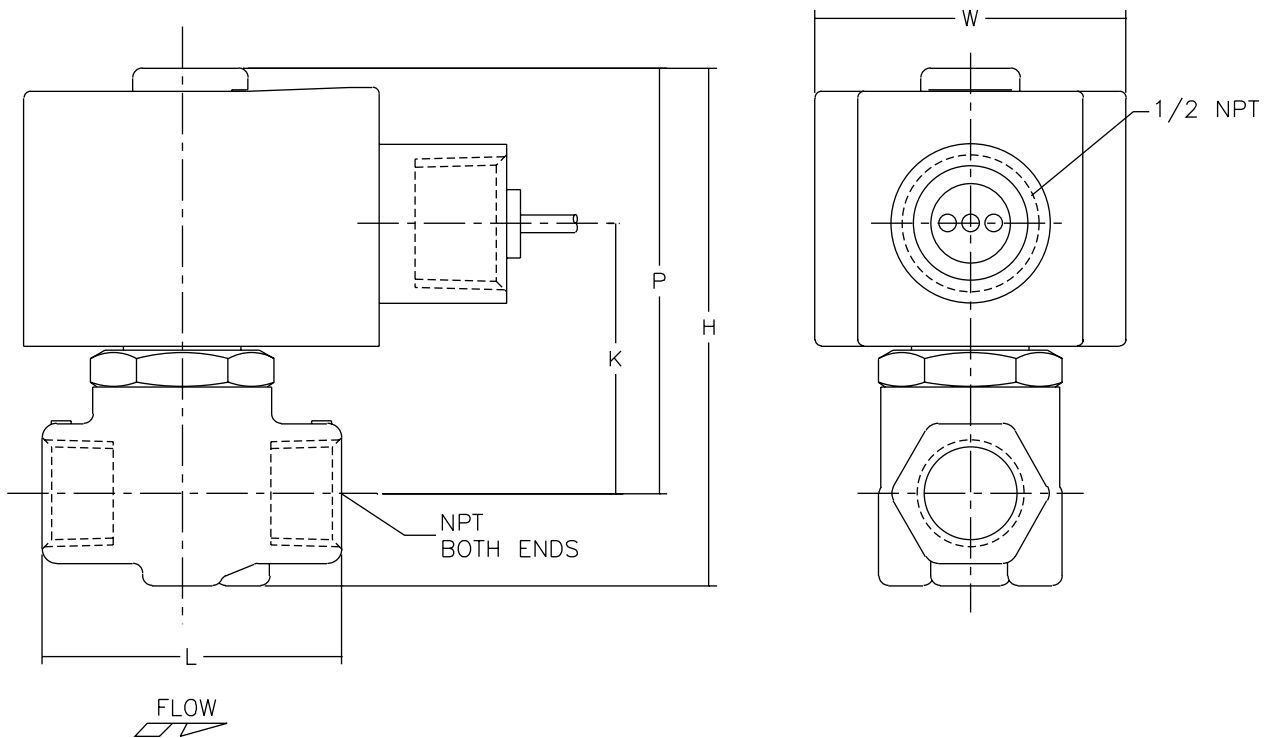

Dimensions: inches (mm)

Constr. Ref. 4

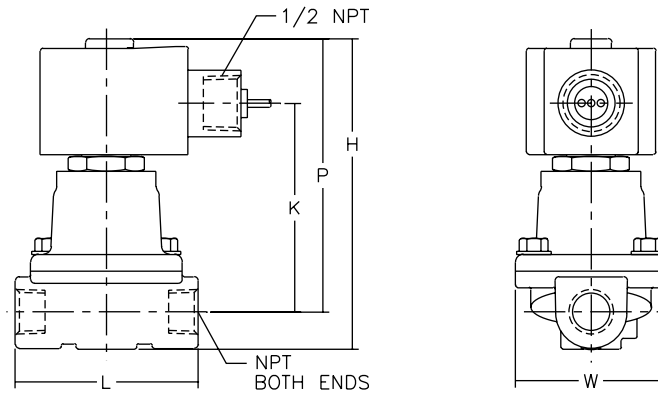

Constr. Ref. 5, 6, 7

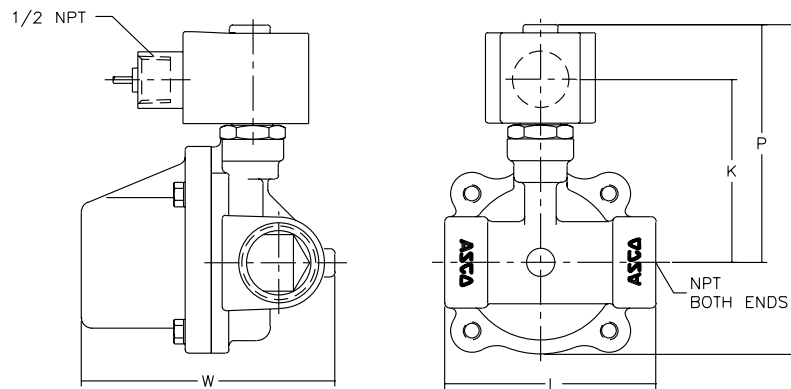

Constr. Ref. 8

