

Features

- Hot water service to 210 psi differential @ 210°F; Steam service to 125 psi differential @ 353°F
- Specify these valves for the high-temperature applications found in laundries, molding, steam atomization, sterilizers, autoclaves, and many others
 - Series 8263: direct acting miniature valves
 - Series 8267: direct acting straight-through, self-cleaning design
 - Series 8210/8220: pilot operated diaphragm valves
 - Series 8220: pilot operated diaphragm and piston valves; floating PTFE diaphragms or stainless steel pistons with EPDM or PTFE discs
 - Series 8221: slow-closing, anti-water hammer design
 - Series 8222: pilot operated diaphragm and piston valves. Y-body floating piston design

Construction

Valve Parts in Contact with Fluids		
Common Parts		
Body	Brass	Stainless Steel
Core Tube	305 Stainless Steel	
Core and Plugnut	430F Stainless Steel	
Springs	302 Stainless Steel	
Shading Coil	Copper	Silver
8210HW Series		
Seals, Discs, and Diaphragms	EPDM	
8263 Series		
Seals	EPDM or PTFE	
Disc	EPDM or PTFE	
8220/8221 Series		
Piston/Diaphragm	Stainless Steel/PTFE	
Discs	EPDM or PTFE	
Seals	EPDM, PTFE or TFE/P	
8222 Series		
Seals, Discs, and Diaphragms	TFE/P, EPDM and/or PTFE	
Piston	Brass or PTFE	
8267 Series		
Seals	FKM, PTFE	
Disc	Stainless Steel	
Seat	Glass-Filled PTFE	

Electrical

Standard Coil and Class of Insulation	Const. Ref.	Watt Rating and Power Consumption				Spare Coil Part Number			
		DC Watts	AC			General Purpose		Explosionproof	
			Watts	VA Holding	VA Inrush	AC	DC	AC	DC
F	1,2,36,38,39,40,41,42	-	6.1	16	30	238210	-	238214	-
F	4, 8, 33, 50	-	6.1	16	40	238210	-	238214	-
H	4	-	6.1	16	40	238410	-	238414	-
F	32-35	11.6	-	-	-	-	238710	-	238714
F	5,7,10,14,15,28,30,32,34,51,52,53	-	10.1	25	70	238610	-	238614	-
F	16,17,18	-	10.1	25	50	238610	-	238614	-
H	3,31	-	10.1	25	50	238810	-	238814	-
H	9,12,14,51,52,53	-	10.1	25	70	238810	-	238814	-
H	51-52	15.6	-	-	-	-	238910	-	238914
F	21-27,43-49	-	16.1	35	95	272610	-	272614	-
H	21-27	-	16.1	35	95	272810	-	272814	-
H	19-20	-	16.1	35	180	272810	-	272814	-
H	3,31	-	17.1	40	70	238810	-	238814	-
H	6,11,29	-	17.1	40	93	238810	-	238814	-
H	13	-	28.2	55	220	224195	-	224195	-

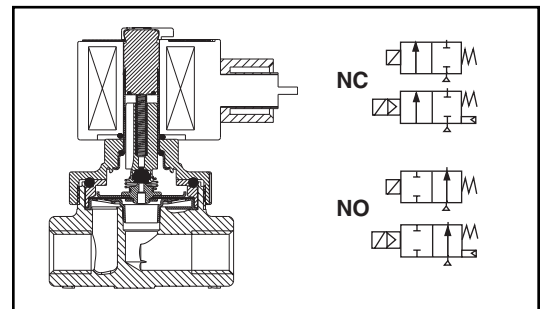

Solenoid Enclosures

Standard: RedHat II - Watertight, Types 1, 2, 3, 3S, 4, and 4X; Red-Hat - Type 1.

Optional: RedHat II - Explosionproof and Watertight, Types 3, 3S, 4, 4X, 6, 6P, 7, and 9; RedHat - Explosionproof and Raintight, Types 3, 7, and 9. (To order, add prefix "EF" to catalog number.)

See *Optional Features Section* for other available options.

Nominal Ambient Temp. Ranges

RedHat II AC: 32°F to 125°F (0°C to 52°C)

For 8263 Steam/Hot Water Series

RedHat II AC: 32°F to 131°F (0°C to 55°C)

For 8210 Hot Water Series

RedHat II DC: 32°F to 104°F (0°C to 40°C)

For 8220 Steam/Hot Water Series

RedHat II DC: 32°F to 125°F (0°C to 52°C)

Refer to *Engineering Section* for details.

Approvals

Most are UL listed, CSA certified, and meet applicable CE directives. *Contact ASCO for details.*

Important: Explosionproof Catalog Numbers EF8210HW, EF8220, EF8221HW, and EF8263 (except G300-306) are not UL listed. They are suitable for Types 4 & 7 (A-D), and 9 (E, F, & G for Class F; E for class H coils) only, and have a temperature range code of T3B (Class F) or T3A (Class H).

SPECIAL SERVICE VALVES

Specifications (English units)

Pipe Size (ins.)	Orifice Size (ins.)	Cv Flow Factor	Operating Pressure Differential (psi)			Max. Fluid Temp. °F		Brass Body		AC Watt Rating/ Class of Coil Insulation	
			Hot Water			Hot Water		Catalog Number	Const. Ref.	AC	DC
			Min.	Max. AC	Max. DC	AC	DC				
HOT WATER SERVICE ONLY - NORMALLY CLOSED (Closed when de-energized), EPDM Diaphragm											
3/8	5/8	3	0 ②	100	40	210	150	8210G093HW	32	10.1/F	11.6/F
3/8	5/8	3	5	125	100	210	150	8210G001HW	33	6.1/F	11.6/F
1/2	5/8	4	0 ②	100	40	210	150	8210G094HW	32	10.1/F	11.6/F
1/2	5/8	4	5	125	100	210	150	8210G002HW	33	6.1/F	11.6/F
3/4	3/4	5	0 ②	100	40	210	150	8210G095HW	34	10.1/F	11.6/F
3/4	3/4	5	5	125	100	210	150	8210G009HW	35	6.1/F	11.6/F
HOT WATER SERVICE ONLY - SLOW CLOSING - NORMALLY CLOSED (Closed when de-energized), EPDM Disc											
3/8	9/16	3	5 ①	150	-	210	-	8221G001HW	36	6.1/F	-
1/2	9/16	3.5	5 ①	150	-	210	-	8221G003HW	36	6.1/F	-
3/4	3/4	5.5	5 ①	150	-	210	-	8221G005HW	36	6.1/F	-
1	1	11.5	5 ①	150	-	210	-	8221G007HW	38	6.1/F	-
1 1/4	1 1/8	13	5 ①	150	-	210	-	8221G009HW	39	6.1/F	-
1 1/2	1 1/4	24	5 ①	150	-	210	-	8221G011HW	40	6.1/F	-
2	1 3/4	36	5 ①	150	-	210	-	8221G013HW	41	6.1/F	-
2 1/2	1 3/4	38	5 ①	150	-	210	-	8221G015HW	42	6.1/F	-
HOT WATER SERVICE ONLY - SLOW CLOSING - NORMALLY OPEN (Open when de-energized), EPDM Disc											
3/8	9/16	3	5 ①	150	-	210	-	8221G021HW	43	16.1/F	-
1/2	9/16	3.5	5 ①	150	-	210	-	8221G023HW	43	16.1/F	-
3/4	3/4	5.5	5 ①	150	-	210	-	8221G025HW	44	16.1/F	-
1	1	11.5	5 ①	150	-	210	-	8221G027HW	45	16.1/F	-
1 1/4	1 1/8	13	5 ①	150	-	210	-	8221G029HW	46	16.1/F	-
1 1/2	1 1/4	24	5 ①	150	-	210	-	8221G031HW	47	16.1/F	-
2	1 3/4	36	5 ①	150	-	210	-	8221G033HW	48	16.1/F	-
2 1/2	1 3/4	38	5 ①	150	-	210	-	8221G035HW	49	16.1/F	-

Pipe Size (ins.)	Orifice Size (ins.)	Cv Flow Factor	Operating Pressure Differential (psi)				Max. Fluid Temp. °F				Brass Body		Stainless Steel Body		Watt Rating/Class of Coil Insulation		
			Max. AC		Max. DC		AC		DC		Catalog Number	Const. Ref.	Catalog Number	Const. Ref.	AC	DC	
			Min.	Hot Water	Steam	Hot Water	Steam	Hot Water	Steam	Hot Water							
STEAM/HOT WATER SERVICE - DIRECT ACTING - NORMALLY CLOSED (Closed when de-energized), Stainless Steel Seat, EPDM ③, or PTFE Disc																	
1/4	1/8	0.35	0	50	150	-	-	298	210	-	-	8263H053 ③	1	-	-	6.1/F	-
1/4	1/8	0.35	0	90	150	-	-	331	210	-	-	8263H059	1	-	-	6.1/F	-
1/4	5/32	0.52	0	110	210	-	-	344	210	-	-	8263H300	2	-	-	10.1/H	-
1/4	7/32	0.73	0	70	95	-	-	316	210	-	-	8263H301	2	-	-	10.1/H	-
1/4	9/32	0.88	0	60	60	-	-	307	210	-	-	8263H303	2	-	-	17.1/H	-
3/8	1/8	0.35	0	125	210	-	-	353	210	-	-	8263H304	3	8263H318	3	10.1/H	-
3/8	5/32	0.52	0	110	200	-	-	344	210	-	-	8263H305	3	8263H319	3	10.1/H	-
3/8	7/32	0.85	0	70	95	-	-	316	210	-	-	8263H306	3	8263H320	3	10.1/H	-
3/8	9/32	1.0	0	60	60	-	-	307	210	-	-	8263H308	3	8263H321	3	17.1/H	-
STEAM/HOT WATER SERVICE - PILOT OPERATED - NORMALLY CLOSED (Closed when de-energized)																	
1/4	3/8	1.2	1	80	-	-	-	324	-	-	-	8222G068	4	-	-	6.1/F	-
1/4	3/8	1.2	1	125	-	-	-	353	-	-	-	8222G070	4	-	-	6.1/H	-
3/8	3/8	2.5	1	80	-	-	-	324	-	-	-	8222G064	4	-	-	6.1/F	-
3/8	3/8	2.5	1	125	-	-	-	353	-	-	-	8222G074	4	-	-	6.1/H	-
3/8	1/2	4.4	5	50	150	-	-	300	210	-	-	8220G401	50	-	-	6.1/F	-
3/8	1/2	4.4	0	50	150	50	100	300	210	300	210	8220G402	51	-	-	10.1/F	15.6/H
3/8	1/2	4.4	5	125	150	-	-	353	210	-	-	8220G403*	51	-	-	10.1/H	-
3/8	5/8	3.0	5	50	150	-	-	300	210	-	-	8222G001	5	-	-	10.1/F	-
1/2	3/8	2.5	1	80	-	-	-	324	-	-	-	8222G066	4	-	-	6.1/F	-
1/2	3/8	2.5	1	125	-	-	-	353	-	-	-	8222G076	4	-	-	6.1/H	-
1/2	1/2	3.6	2	125	-	-	-	353	-	-	-	8222G047	9	-	-	10.1/H	-
1/2	5/8	4.0	0	50	-	-	-	300	-	-	-	8222G094	7	8222G060	28	10.1/F	-
1/2	5/8	4.0	0	125	-	-	-	353	-	-	-	8222G002	6	-	-	17.1/H	-
1/2	1/2	4.7	5	50	150	-	-	300	210	-	-	8220G404	50	-	-	6.1/F	-
1/2	1/2	4.7	0	50	150	50	100	300	210	300	210	8220G405	51	-	-	10.1/F	15.6/H
1/2	1/2	4.7	5	125	150	-	-	353	210	-	-	8220G406*	51	-	-	10.1/H	-

SPECIAL SERVICE VALVES

Specifications (English units continued)

Pipe Size (ins.)	Orifice Size (ins.)	Cv Flow Factor	Operating Pressure Differential (psi)				Max. Fluid Temp. °F				Brass Body		Stainless Steel Body		Watt Rating/Class of Coil Insulation		
			Min.	Max. AC		Max. DC		AC		DC		Catalog Number	Const. Ref.	Catalog Number	Const. Ref.	AC	DC
				Steam	Hot Water	Steam	Hot Water	Steam	Hot Water	Steam	Hot Water						
STEAM/HOT WATER SERVICE - PILOT OPERATED - NORMALLY CLOSED (Closed when de-energized)																	
3/4	5/8	4.5	0	50	-	-	-	300	-	-	-	-	-	8222G062	28	10.1/F	-
3/4	5/8	4.5	0	125	-	-	-	353	-	-	-	-	-	8222G088	29	17.1/H	-
3/4	3/4	5.0	0	50	-	-	-	300	-	-	-	8222G095	10	-	-	10.1/F	-
3/4	3/4	8.8	5	50	150	-	-	300	210	-	-	8220G407	8	-	-	6.1/F	-
3/4	3/4	8.8	0	50	150	50	100	300	210	300	210	8220G408	52	-	-	10.1/F	15.6/H
3/4	3/4	8.8	5	125	150	-	-	353	210	-	-	8220G409*	52	-	-	10.1/H	-
3/4	3/4	5.0	0	125	-	-	-	353	-	-	-	8222G003	11	-	-	17.1/H	-
3/4	1/2	4.6	2	125	-	-	-	353	-	-	-	8222G049	9	-	-	10.1/H	-
3/4	1/2	4.6	5	200	-	-	-	388	-	-	-	8222G005	12	-	-	10.1/H	-
1	1	11.2	5	125	-	-	-	353	-	-	-	-	-	8222G089	30	10.1/F	-
1	1	13.5	5 ①	50	150	-	-	300	210	-	-	8220G007	14	-	-	10.1/F	-
1	1	13.5	5 ①	125	150	-	-	353	210	-	-	8220G025	14	-	-	10.1/H	-
1	1	11.5	5	50	150	-	-	300	210	-	-	8220G410	53	-	-	10.1/F	-
1	1	11.5	5	125	150	-	-	353	210	-	-	8220G411*	53	-	-	10.1/H	-
1	1	13.0	0	200	-	-	-	388	-	-	-	822 099**	13	-	-	28.2/H	-
1 1/4	1 1/8	15	5 ①	50	150	-	-	300	210	-	-	8220G009 ③	15	-	-	10.1/F	-
1 1/4	1 1/8	15	5 ①	125	150	-	-	353	210	-	-	8220G027	15	-	-	10.1/H	-
1 1/2	1 1/4	22.5	5 ①	50	150	-	-	300	210	-	-	8220G011 ③	16	-	-	10.1/F	-
1 1/2	1 1/4	22.5	5 ①	125	150	-	-	353	210	-	-	8220G029	16	-	-	10.1/H	-
2	1 3/4	43	5 ①	50	150	-	-	300	210	-	-	8220G013 ③	17	-	-	10.1/F	-
2	1 3/4	43	5 ①	125	150	-	-	353	210	-	-	8220G031	17	-	-	10.1/H	-
2 1/2	1 3/4	45	5 ①	50	150	-	-	300	210	-	-	8220G015 ③	18	-	-	10.1/F	-
2 1/2	1 3/4	45	5 ①	125	150	-	-	353	210	-	-	8220G033	18	-	-	10.1/H	-
STEAM SERVICE - DIRECT ACTING, STRAIGHT-THROUGH DESIGN - NORMALLY CLOSED (Closed when de-energized)																	
3/8	1/4	1.5	0	75	-	-	-	320	-	-	-	8267G001	19	-	-	16.1/H	-
3/8	3/8	5.1	0	30	-	-	-	280	-	-	-	8267G003	19	-	-	16.1/H	-
1/2	1/4	1.4	0	75	-	-	-	320	-	-	-	8267G005	19	-	-	16.1/H	-
1/2	3/8	4.5	0	15	-	-	-	250	-	-	-	8267G007	19	-	-	16.1/H	-
3/4	3/8	5.4	0	30	-	-	-	280	-	-	-	8267G017	20	-	-	16.1/H	-
3/4	1/2	9.7	0	15	-	-	-	250	-	-	-	8267G019	20	-	-	16.1/H	-
STEAM SERVICE - DIRECT ACTING, STRAIGHT-THROUGH DESIGN - NORMALLY OPEN (Open when de-energized)																	
3/8	1/4	1.5	0	75	-	-	-	320	-	-	-	8267G009	19	-	-	16.1/H	-
3/8	3/8	5.1	0	30	-	-	-	280	-	-	-	8267G011	19	-	-	16.1/H	-
1/2	1/4	1.4	0	75	-	-	-	320	-	-	-	8267G013	19	-	-	16.1/H	-
1/2	3/8	4.5	0	15	-	-	-	250	-	-	-	8267G015	19	-	-	16.1/H	-
3/4	3/8	5.4	0	25	-	-	-	267	-	-	-	8267G021	20	-	-	16.1/H	-
3/4	1/2	9.7	0	15	-	-	-	250	-	-	-	8267G023	20	-	-	16.1/H	-
STEAM/HOT WATER SERVICE - PILOT OPERATED - NORMALLY OPEN (Open when de-energized)																	
3/8	9/16	3	5	125	150	-	-	353	210	-	-	8220G091	21	-	-	16.1/H	-
1/2	9/16	4	5	125	150	-	-	353	210	-	-	8220G093	21	-	-	16.1/H	-
3/4	3/4	5	5	125	150	-	-	353	210	-	-	8220G095	22	-	-	16.1/H	-
1	1	13.5	5	125	150	-	-	353	210	-	-	8220G097	23	-	-	16.1/H	-
1 1/4	1 1/8	15	5	125	150	-	-	353	210	-	-	8220G099	24	-	-	16.1/H	-
1 1/2	1 1/4	22.5	5	125	150	-	-	353	210	-	-	8220G101	25	-	-	16.1/H	-
2	1 3/4	43	5	125	150	-	-	353	210	-	-	8220G103	26	-	-	16.1/H	-
2 1/2	1 3/4	45	5	125	150	-	-	353	210	-	-	8220G105	27	-	-	16.1/F	-

① Once opened at higher pressure, valve will remain open to 3 psi at inlet.
 ② 0 psi on AC construction, 1/4 psi on DC construction.
 ③ EPDM disc.
 * Ambient temperature range 32°F - 140°F; ** Ambient temperature range 32°F - 77°F

SPECIAL SERVICE VALVES

Specifications (Metric units)

Pipe Size (ins.)	Orifice Size (mm)	Kv Flow Factor (m3/h)	Operating Pressure Differential (bar)			Max. Fluid Temp. °C		Brass Body		AC Watt Rating/ Class of Coil Insulation	
			Hot Water			Hot Water		Catalog Number	Const. Ref.	AC	DC
			Min.	Max. AC	Max. DC	AC	DC				
HOT WATER SERVICE ONLY - NORMALLY CLOSED (Closed when de-energized), EPDM Diaphragm											
3/8	16	2.57	0 @	6.9	2.8	98	65	8210G093HW	32	10.1/F	11.6/F
3/8	16	2.57	0.3	8.6	6.9	98	65	8210G001HW	33	6.1/F	11.6/F
1/2	16	3.43	0 @	6.9	2.8	98	65	8210G094HW	32	10.1/F	11.6/F
1/2	16	3.43	0.3	8.6	6.9	98	65	8210G002HW	33	6.1/F	11.6/F
3/4	19	4.29	0 @	6.9	2.8	98	65	8210G095HW	34	10.1/F	11.6/F
3/4	19	4.29	0.03	8.6	6.9	98	65	8210G009HW	35	6.1/F	11.6/F
HOT WATER SERVICE ONLY - SLOW CLOSING - NORMALLY CLOSED (Closed when de-energized), EPDM Disc											
3/8	14	2.57	0.3 ①	10.3	-	98	-	8221G001HW	36	6.1/F	-
1/2	14	3.00	0.3 ①	10.3	-	98	-	8221G003HW	36	6.1/F	-
3/4	19	4.71	0.3 ①	10.3	-	98	-	8221G005HW	36	6.1/F	-
1	25	9.86	0.3 ①	10.3	-	98	-	8221G007HW	38	6.1/F	-
1 1/4	29	11.14	0.3 ①	10.3	-	98	-	8221G009HW	39	6.1/F	-
1 1/2	32	20.57	0.3 ①	10.3	-	98	-	8221G011HW	40	6.1/F	-
2	44	30.86	0.3 ①	10.3	-	98	-	8221G013HW	41	6.1/F	-
2 1/2	44	32.57	0.3 ①	10.3	-	98	-	8221G015HW	42	6.1/F	-
HOT WATER SERVICE ONLY - SLOW CLOSING - NORMALLY OPEN (Open when de-energized), EPDM Disc											
3/8	14	2.57	0.3 ①	10.3	-	98	-	8221G021HW	43	16.1/F	-
1/2	14	3.00	0.3 ①	10.3	-	98	-	8221G023HW	43	16.1/F	-
3/4	19	4.71	0.3 ①	10.3	-	98	-	8221G025HW	44	16.1/F	-
1	25	9.86	0.3 ①	10.3	-	98	-	8221G027HW	45	16.1/F	-
1 1/4	29	11.14	0.3 ①	10.3	-	98	-	8221G029HW	46	16.1/F	-
1 1/2	32	20.57	0.3 ①	10.3	-	98	-	8221G031HW	47	16.1/F	-
2	44	30.86	0.3 ①	10.3	-	98	-	8221G033HW	48	16.1/F	-
2 1/2	44	32.57	0.3 ①	10.3	-	98	-	8221G035HW	49	16.1/F	-

Pipe Size (ins.)	Orifice Size (mm)	Kv Flow Factor (m3/h)	Operating Pressure Differential (bar)				Max. Fluid Temp. °C				Brass Body		Stainless Steel Body		Watt Rating/Class of Coil Insulation		
			Max. AC		Max. DC		AC		DC		Catalog Number	Const. Ref.	Catalog Number	Const. Ref.	AC	DC	
			Min.	Steam	Hot Water	Steam	Hot Water	Steam	Hot Water	Steam							Hot Water
STEAM/HOT WATER SERVICE - DIRECT ACTING - NORMALLY CLOSED (Closed when de-energized), Stainless Steel Seat, EPDM ③, or PTFE Disc																	
1/4	3	0.30	0	3.4	10.3	-	-	146	99	-	-	8263H053 ③	1	-	-	6.1/F	-
1/4	3	0.30	0	6.2	10.3	-	-	164	99	-	-	8263H059	1	-	-	6.1/F	-
1/4	4	0.45	0	7.6	14.5	-	-	172	99	-	-	8263H300	2	-	-	10.1/H	-
1/4	6	0.63	0	4.8	6.6	-	-	156	99	-	-	8263H301	2	-	-	10.1/H	-
1/4	7	0.76	0	4.1	4.1	-	-	151	99	-	-	8263H303	2	-	-	17.1/H	-
3/8	3	0.30	0	8.6	14.5	-	-	177	99	-	-	8263H304	3	8263H318	3	10.1/H	-
3/8	4	0.45	0	7.6	13.8	-	-	172	99	-	-	8263H305	3	8263H319	3	10.1/H	-
3/8	6	0.74	0	4.8	6.6	-	-	156	99	-	-	8263H306	3	8263H320	3	10.1/H	-
3/8	7	0.87	0	4.1	4.1	-	-	151	99	-	-	8263H308	3	8263H321	3	17.1/H	-
STEAM/HOT WATER SERVICE - PILOT OPERATED - NORMALLY CLOSED (Closed when de-energized)																	
1/4	10	1.03	0.07	6	-	-	-	161	-	-	-	8222G068	4	-	-	6.1/F	-
1/4	10	1.03	0.07	9	-	-	-	177	-	-	-	8222G070	4	-	-	6.1/H	-
3/8	10	2.14	0.07	6	-	-	-	161	-	-	-	8222G064	4	-	-	6.1/F	-
3/8	10	2.14	0.07	9	-	-	-	177	-	-	-	8222G074	4	-	-	6.1/H	-
3/8	12.7	3.8	0.3	3	10	-	-	147	98	-	-	8220G401	50	-	-	6.1/F	-
3/8	12.7	3.8	0	3	10	3.4	6.9	147	98	147	98	8220G402	51	-	-	10.1/F	15.6/H
3/8	12.7	3.8	0.3	9	10	-	-	177	98	-	-	8220G403*	51	-	-	10.1/H	-
3/8	16	2.57	0	9	-	-	-	177	-	-	-	8222G001	6	-	-	17.1/H	-
1/2	10	2.14	0.07	6	-	-	-	161	-	-	-	8222G066	4	-	-	6.1/F	-
1/2	10	2.14	0.07	9	-	-	-	177	-	-	-	8222G076	4	-	-	6.1/H	-
1/2	13	3.09	0.14	9	-	-	-	177	-	-	-	8222G047	9	-	-	10.1/H	-
1/2	16	3.43	0	3	-	-	-	147	-	-	-	8222G094	7	8222G060	28	10.1/F	-
1/2	16	3.43	0	9	-	-	-	177	-	-	-	8222G002	6	-	-	17.1/H	-
1/2	12.7	4	0.3	3	10	-	-	147	98	-	-	8220G404	50	-	-	6.1/F	-
1/2	12.7	4	0	3	10	3.4	6.9	147	98	147	98	8220G405	51	-	-	10.1/F	15.6/H
1/2	12.7	4	0.3	9	10	-	-	177	98	-	-	8220G406*	51	-	-	10.1/H	-

SPECIAL SERVICE VALVES

Specifications (Metric units continued)

Pipe Size (ins.)	Orifice Size (mm)	Kv Flow Factor (m3/h)	Operating Pressure Differential (bar)						Max. Fluid Temp. °C				Brass Body		Stainless Steel Body		Watt Rating/Class of Coil Insulation		
			Max. AC			Max. DC			AC		DC		Catalog Number	Const. Ref.	Catalog Number	Const. Ref.	AC	DC	
			Min.	Steam	Hot Water	Steam	Hot Water	Steam	Hot Water	Steam	Hot Water								
STEAM/HOT WATER SERVICE - PILOT OPERATED - NORMALLY CLOSED (Closed when de-energized)																			
3/4	16	3.86	0	3	-	-	-	147	-	-	-	-	-	-	8222G062	28	10.1/F	-	
3/4	16	3.86	0	9	-	-	-	177	-	-	-	-	-	-	8222G088	29	17.1/H	-	
3/4	19	4.29	0	3	-	-	-	147	-	-	-	-	-	8222G095	10	-	10.1/F	-	
3/4	19	7.5	0.3	3	10	-	-	147	98	-	-	-	-	8220G407	8	-	6.1/F	-	
3/4	19	7.5	0	3	10	3.4	6.9	147	98	147	98	-	-	8220G408	52	-	10.1/F	15.6/H	
3/4	19	7.5	0.3	9	10	-	-	177	98	-	-	-	-	8220G409*	52	-	10.1/H	-	
3/4	19	4.29	0	9	-	-	-	177	-	-	-	-	-	8222G003	11	-	17.1/H	-	
3/4	13	3.94	0.14	9	-	-	-	177	-	-	-	-	-	8222G049	9	-	10.1/H	-	
3/4	13	3.94	0.3	14	-	-	-	196	-	-	-	-	-	8222G005	12	-	10.1/H	-	
1	25	9.60	0.3	9	-	-	-	177	-	-	-	-	-	-	-	8222G089	30	10.1/F	-
1	25	11.57	0.3①	3	10	-	-	147	98	-	-	-	-	8220G007	14	-	10.1/F	-	
1	25	11.57	0.3①	3	10	-	-	177	98	-	-	-	-	8220G025	14	-	10.1/H	-	
1	25	10	0.3	3	10	-	-	147	98	-	-	-	-	8220G410	53	-	10.1/F	-	
1	25	10	0.3	9	10	-	-	177	98	-	-	-	-	8220G411*	53	-	10.1/H	-	
1	25	11.57	0.3	9	-	-	-	177	-	-	-	-	-	8222 099**	13	-	28.2/H	-	
1 1/4	25	11.14	0	14	-	-	-	196	-	-	-	-	-	8220G009 ③	15	-	10.1/F	-	
1 1/4	29	12.86	0.3①	3	10	-	-	147	98	-	-	-	-	8220G027	15	-	10.1/H	-	
1 1/2	29	12.86	0.3①	9	10	-	-	177	98	-	-	-	-	8220G011 ③	16	-	10.1/F	-	
1 1/2	32	19.29	0.3①	3	10	-	-	147	98	-	-	-	-	8220G029	16	-	10.1/H	-	
2	32	19.29	0.3①	9	10	-	-	177	98	-	-	-	-	8220G013 ③	17	-	10.1/F	-	
2	44	36.86	0.3①	3	10	-	-	147	98	-	-	-	-	8220G031	17	-	10.1/H	-	
2 1/2	44	36.86	0.3①	9	10	-	-	177	98	-	-	-	-	8220G015 ③	18	-	10.1/F	-	
2 1/2	44	38.57	0.3①	3	10	-	-	147	98	-	-	-	-	8220G033	18	-	10.1/H	-	
STEAM SERVICE - DIRECT ACTING, STRAIGHT-THROUGH DESIGN - NORMALLY CLOSED (Closed when de-energized)																			
3/8	6	1.29	0	5	-	-	-	158	-	-	-	-	-	8267G001	19	-	16.1/H	-	
3/8	10	4.37	0	2	-	-	-	136	-	-	-	-	-	8267G003	19	-	16.1/H	-	
1/2	6	1.20	0	5	-	-	-	158	-	-	-	-	-	8267G005	19	-	16.1/H	-	
1/2	10	3.86	0	1	-	-	-	120	-	-	-	-	-	8267G007	19	-	16.1/H	-	
3/4	10	4.63	0	2	-	-	-	136	-	-	-	-	-	8267G017	20	-	16.1/H	-	
3/4	13	8.31	0	1	-	-	-	120	-	-	-	-	-	8267G019	20	-	16.1/H	-	
STEAM SERVICE - DIRECT ACTING, STRAIGHT-THROUGH DESIGN - NORMALLY OPEN (Open when de-energized)																			
3/8	6	1.29	0	5	-	-	-	158	-	-	-	-	-	8267G009	19	-	16.1/H	-	
3/8	10	4.37	0	2	-	-	-	136	-	-	-	-	-	8267G011	19	-	16.1/H	-	
1/2	6	1.20	0	5	-	-	-	158	-	-	-	-	-	8267G013	19	-	16.1/H	-	
1/2	10	3.86	0	1	-	-	-	120	-	-	-	-	-	8267G015	19	-	16.1/H	-	
3/4	10	4.63	0	2	-	-	-	129	-	-	-	-	-	8267G021	20	-	16.1/H	-	
3/4	13	8.31	0	1	-	-	-	120	-	-	-	-	-	8267G023	20	-	16.1/H	-	
STEAM/HOT WATER SERVICE - PILOT OPERATED - NORMALLY OPEN (Open when de-energized)																			
3/8	14	2.57	0.3	9	10	-	-	177	98	-	-	-	-	8220G091	21	-	16.1/H	-	
1/2	14	3.43	0.3	9	10	-	-	177	98	-	-	-	-	8220G093	21	-	16.1/H	-	
3/4	19	4.29	0.3	9	10	-	-	177	98	-	-	-	-	8220G095	22	-	16.1/H	-	
1	25	11.57	0.3	9	10	-	-	177	98	-	-	-	-	8220G097	23	-	16.1/H	-	
1 1/4	29	12.86	0.3	9	10	-	-	177	98	-	-	-	-	8220G099	24	-	16.1/H	-	
1 1/2	32	19.29	0.3	9	10	-	-	177	98	-	-	-	-	8220G101	25	-	16.1/H	-	
2	44	36.86	0.3	9	10	-	-	177	98	-	-	-	-	8220G103	26	-	16.1/H	-	
2 1/2	44	38.57	0.3	9	10	-	-	177	98	-	-	-	-	8220G105	27	-	16.1/F	-	

① Once opened at higher pressure, valve will remain open to 0.2 bar at inlet.

② 0 bar on AC construction, 0.02 bar on DC construction.

③ EPDM disc.

* Ambient temperature range 0°C - 60°C; ** Ambient temperature range 0°C - 25°C

Dimensions inches (mm)

Const. Ref.		H	K	L	P	W
1	ins.	3.12	1.79	1.56	2.76	1.95
	mm	79	45	40	70	50
2	ins.	2.96	1.72	1.56	2.60	1.69
	mm	75	44	40	66	43
3	ins.	3.01	1.68	1.88	2.57	1.69
	mm	76	43	48	65	43
4	ins.	4.17	3.25	2.28	3.63	1.69
	mm	106	83	58	92	43
5	ins.	4.05	2.52	2.75	3.48	2.28
	mm	103	64	70	88	58
7	ins.	3.84	2.31	2.75	3.28	2.29
	mm	98	59	70	83	58
8	ins.	4.00	2.45	2.88	3.34	2.83
	mm	102	62	73	85	72
9	ins.	4.81	3.62	2.75	4.01	1.95
	mm	122	92	70	102	50
10	ins.	4.14	2.47	2.81	3.44	2.29
	mm	105	63	71	87	58
12	ins.	4.81	3.63	2.75	4.01	1.95
	mm	122	92	70	102	50
32	ins.	3.84	2.31	2.75	3.28	2.29
	mm	98	59	70	83	58
33	ins.	3.36	1.94	2.75	2.80	2.28
	mm	85	49	70	71	58
34	ins.	4.13	2.47	2.81	3.44	2.29
	mm	105	63	71	87	58
35	ins.	3.66	2.10	2.81	2.96	2.28
	mm	93	53	71	75	58
50	ins.	3.94	2.5	2.88	3.4	2.25
	mm	100	63.3	73	86	57
51	ins.	4.1	2.56	2.88	3.54	2.25
	mm	104	65	73	90	57
52	ins.	4.2	2.52	2.88	3.5	2.83
	mm	106	64	73	89	72

Const. Ref. 1, 2, 3

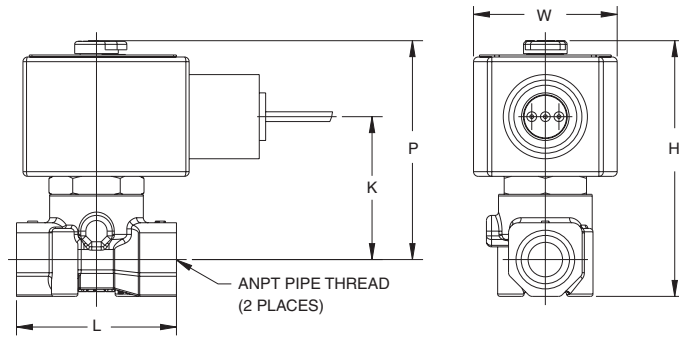

Const. Ref. 4, 9, 12

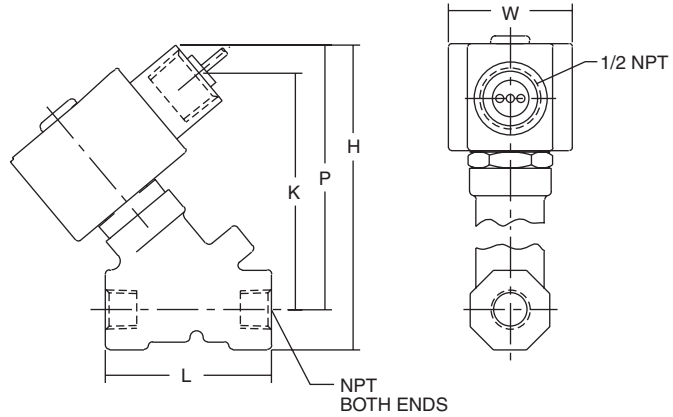

Const. Ref. 8, 50, 51, 52

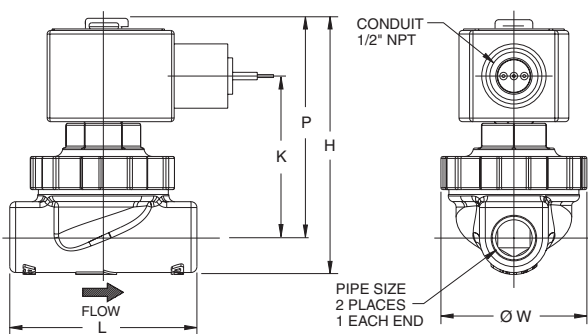

Const. Ref. 5, 7, 10, 32-35

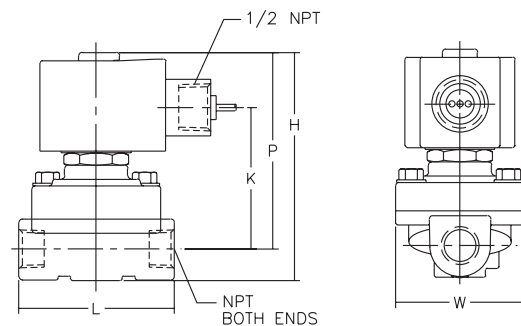

SPECIAL SERVICE VALVES

Dimensions inches (mm)

Const. Ref.		H	K	L	P	W
6	ins.	4.68	3.15	2.75	4.12	2.28
	mm	119	80	70	105	58
11	ins.	4.97	3.45	2.81	4.28	2.28
	mm	126	88	71	109	58
13	ins.	5.82	3.22	3.75	4.19	3.31
	mm	148	82	95	106	84
14	ins.	5.81	3.22	3.75	4.19	3.14
	mm	148	82	95	106	80
15	ins.	5.81	3.22	3.66	4.19	3.56
	mm	148	82	93	106	90
16	ins.	6.29	3.37	4.38	4.34	4.10
	mm	160	86	111	110	104
17	ins.	7.51	3.78	5.06	4.75	4.71
	mm	191	96	129	121	120
18	ins.	7.51	3.78	5.50	4.75	5.18
	mm	191	96	140	121	132
23	ins.	6.46	3.36	3.75	4.86	3.14
	mm	164	85	95	123	80
24	ins.	6.39	3.36	3.66	4.86	3.56
	mm	162	85	93	123	90
25	ins.	6.97	3.51	4.38	5.01	4.10
	mm	177	89	111	127	104
26	ins.	8.18	3.92	5.06	5.42	4.71
	mm	208	100	129	138	120
27	ins.	8.18	3.92	5.50	5.42	5.18
	mm	208	100	140	138	132
29	ins.	5.04	3.34	2.81	4.31	2.28
	mm	128	85	71	109	58
38	ins.	5.64	3.15	3.75	4.01	3.14
	mm	143	80	95	102	80
39	ins.	5.64	3.15	3.66	4.01	3.56
	mm	143	80	93	102	90
40	ins.	6.11	3.30	4.38	4.16	4.10
	mm	155	84	111	106	104
41	ins.	7.35	3.63	5.06	4.58	4.71
	mm	187	92	129	116	120
42	ins.	7.35	3.63	5.50	4.58	5.18
	mm	187	92	140	116	132
45	ins.	6.53	3.36	3.75	4.91	3.14
	mm	166	85	95	125	80
46	ins.	6.46	3.36	3.66	4.91	3.56
	mm	164	85	93	25	90
47	ins.	7.03	3.51	4.38	5.06	4.10
	mm	179	89	111	129	104
48	ins.	8.22	3.97	5.06	5.47	4.71
	mm	209	101	129	139	120
49	ins.	8.22	3.97	5.50	5.47	5.18
	mm	209	101	140	139	132
53	ins.	5.82	3.21	3.75	4.2	3.27
	mm	148	82	95	106	83

* Valves must be mounted with solenoid vertical and upright.

Const. Ref. 6, 11, 13, 29

1/2 NPT OR 7/8 DIA HOLE FOR

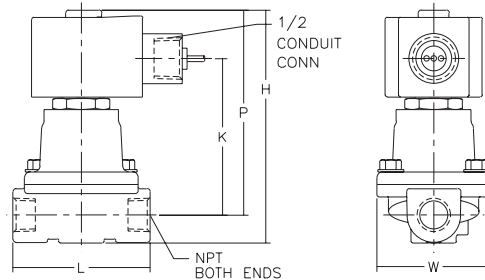

Const. Ref. 19*

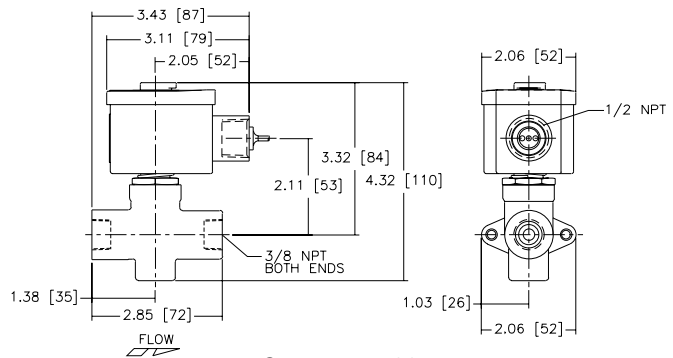

Const. Ref. 20*

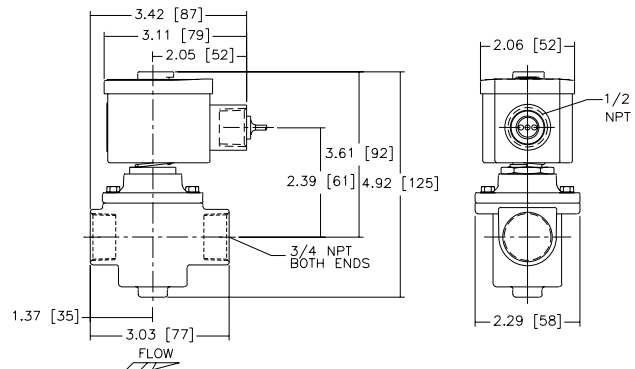

Const. Ref. 14-16, 23-25, 45-49, 53

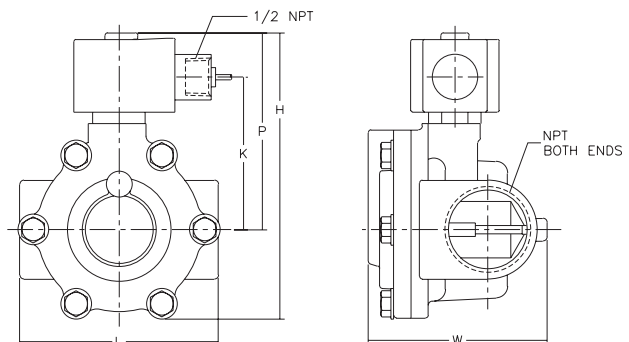

(BOLT PATTERN MAY VARY)

SPECIAL
SERVICE VALVES

Dimensions inches (mm)

Const. Ref.		H	K	L	P	W
21	ins.	5.11	3.13	2.71	4.35	3.58
	mm	130	80	69	111	91
22	ins.	5.30	3.29	2.78	4.51	3.58
	mm	135	84	71	115	91
28	ins.	4.17	2.47	2.81	3.44	2.28
	mm	106	63	71	87	58
30	ins.	5.82	3.22	3.75	4.19	4.44
	mm	148	82	95	106	113
31	ins.	3.25	1.70	2.00	2.67	1.95
	mm	83	43	51	68	50
36	ins.	4.32	2.69	2.71	3.56	3.45
	mm	110	68	69	90	88
43	ins.	5.12	3.14	2.71	4.35	3.65
	mm	130	80	69	111	93
44	ins.	5.30	3.30	2.78	4.51	3.65
	mm	135	84	71	115	93

Const. Ref. 17, 18, 26, 27, 38-42

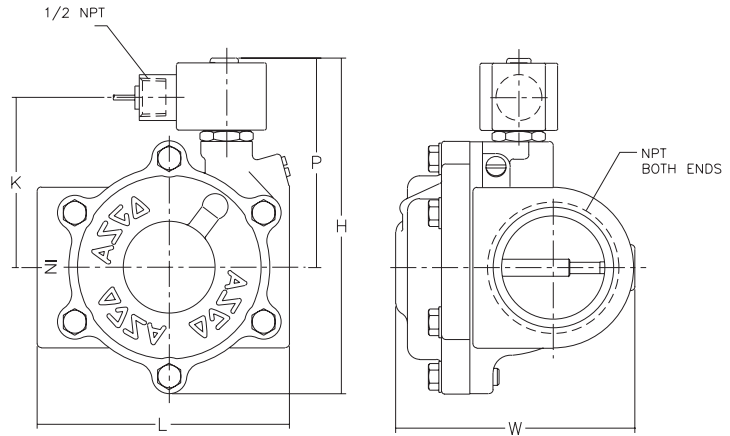

Const. Ref. 28

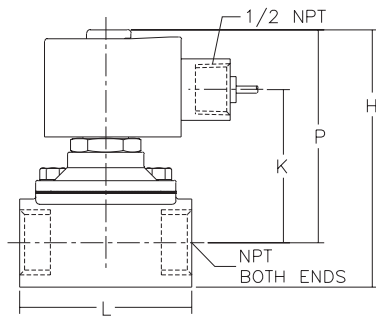

Const. Ref. 30

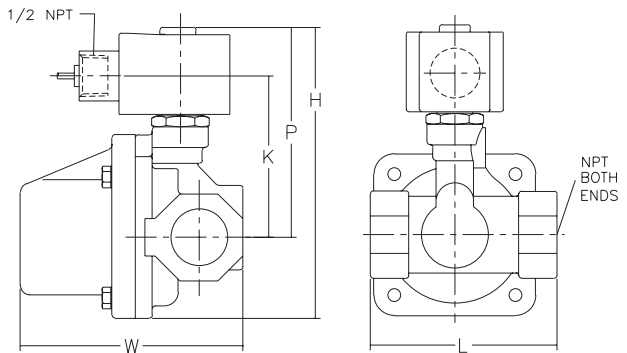

Const. Ref. 31

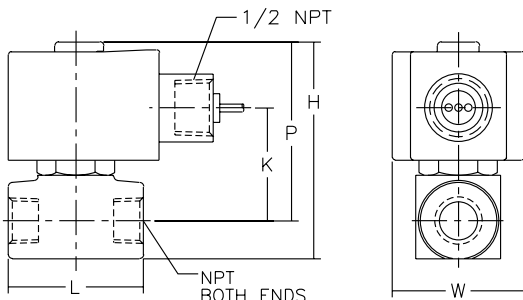

Const. Ref. 21, 22, 36, 43, 44

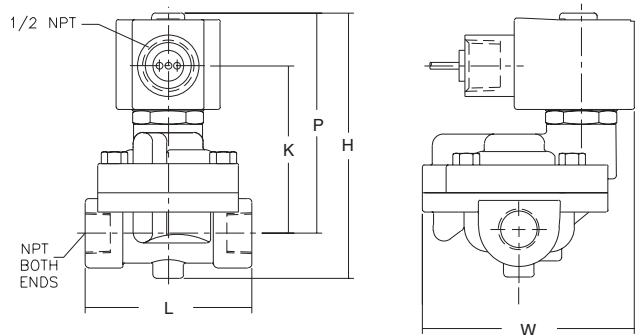

SPECIAL SERVICE VALVES